



MITSUBISHI

**OPERATING INSTRUCTION FOR
VIDEO COPY PROCESSOR**

MODEL P68E

PRECAUTIONS:

In the interest of safety, please observe the following precautions:

WARNING : THIS APPARATUS MUST BE EARTHED.

DO NOT OPERATE THIS UNIT IF CONDENSATION IS PRESENT

If condensation is present inside the Video Copy Processor, the "READY" indicator will be blinking.

Do not press the "PRINT" or "COPY" button to avoid a paper jam.

Do not operate, leave the power switch "ON" for approximately one hour or until all traces of condensation has evaporated.

The "READY" indicator will illuminate when the condensation has evaporated.

Before operating, replace the paper roll. The removed paper roll can be used after all traces of condensation are gone.

Condensation is likely to occur when:

1. The Video Copy Processor is moved from a cold room to a warm room or from outdoors to inside.
2. A cold room is heated quickly;
3. The humidity is very high.

Note: Avoid using the Video Copy Processor where cold air, such as that from an air conditioner, will blow on it directly.

DO NOT PLACE WATER CONTAINERS ON THE UNIT

"In the interest of safety, avoid the handling of liquids beside the set."

Do not place flower vases, and other water-holding containers on the device. If, for some reason, water seeps to the inside of the unit, unplug the power cord from the source outlet, and contact the sales dealer. If used without corrective measures, the unit may be damaged.

PROTECT THE POWER CORD

Damage to the power cord may cause fire or shock hazard. When unplugging, hold by the plug only and remove carefully.

UNPLUG THE POWER CORD DURING A LONG ABSENCE

If you leave your home for an extended period, turn off the MAIN power switch and unplug the power cord.

MAINTAIN GOOD VENTILATION

Ventilation slots and holes are provided on the top, sides and bottom of this unit. Place the unit on a hard and level surface and locate at least 4 inches from walls to ensure proper ventilation.

NEVER INSERT ANY OBJECT INTO THE SET

Foreign objects of any kind inserted into this unit constitute a safety hazard and can cause extensive damage.

DO NOT PLACE ANYTHING ON THE VIDEO COPY PROCESSOR

Heavy objects placed on the Video Copy Processor can cause damage or obstruct proper ventilation.

CARE OF THE CABINET

Unplug and clean with a soft cloth slightly moistened with a mild soap and water solution. Allow to dry completely before operating.

Never use petroleum base solutions or abrasive cleaners.

TO PREVENT PAPER JAMS

1. Do not pull or touch or tear off the thermal paper during the printing process.
2. Do not use a moistened paper roll.

CARE AND USE OF VIDEO COPY PROCESSOR PAPER

1. Four kinds of paper can be used.
 - * K-60N – Normal paper for normal-grade prints.
 - * K-65H/K-65HM – High density paper
 - * K-61S – Super paperSelect paper best suited to your needs.
2. Each grade of paper yields approximately 200 prints per roll.
3. Keep the paper away from sources of heat (ie: direct sunlight, heater's, etc.). Store and use the paper in a temperature range of 32-104°F/0-40°C and relative humidity range of 20-80%.
4. Moving the paper from low temperature conditions to high temperature conditions may cause moisture or dew to form on the paper surface which can result in poor quality prints and/ or paper jamming. Let the paper adjust to room temperature prior to use.
5. Fingerprints, dirt or dust on the surface of the paper may cause poor quality prints.
6. The paper is provided with a red-end warning section which indicates that approximately 2.5 feet of paper is remaining. Print quality may decrease after the red warning section [last 2.5 feet (75 cm)].
7. If paper runs out during operation, the print function stops and the "READY" indicator goes off. Install a new paper roll.
8. Store prints in a low humidity location away from direct sunlight to avoid discoloration or deterioration of the image.
9. When the paper absorbs non-volatile organic solvents such as alcohol, ether and ketone, the image may be affected. Cellophane tapes and soft vinyl chlorides also may cause discoloration or fading.
Also, avoid contact with wet diazo copies as the image may fade away.
10. For correct performance, use one of the specified papers.
11. If the paper is stacked or jammed, refer to the "WHEN PRINTING IS NOT POSSIBLE" section of this instruction booklet.

BEFORE OPERATING

Please review the following important instructions before operating your new MITSUBISHI Video Copy Processor.

LOCATION

1. Choose a location where direct sunlight or other bright light does not fall directly on the Video Copy Processor.
2. Choose a well ventilated location away from radiators or other heat sources and at least 4 inches (10 cm) away from walls.
3. Do not place in the direct air flowing from an air conditioner.

SAFETY TECHNICAL CHECKS

Terms: The safety test has to be done, according to the specified terms of §11 chp.1 MedGV mentioned in the certificate acc. §22 chp.1, §22 chp.2 or acc. to the type approval §5 MedGV or according to the recommendation of the medical set manufacturer.

- Items:
- a) Visual check
Housing, cables, operator controls, readout devise (displays, LED etc.), labels, accessories, instruction manual.
 - b) Function test
Performance check acc. instruction manual, also unity and applicability of set and accessory test.
 - c) Electrical check
Safety electrical test of the configuration in accordance with VDE 0751.

POWER REQUIREMENT

This Video Copy Processor is designed for operation with 220/240 volts, 50 hertz (cycles), alternating current (AC) only.

Never connect to any outlet or power supply having a different voltage or frequency.

FRONT PANEL CONTROLS — LOCATION AND DESCRIPTION

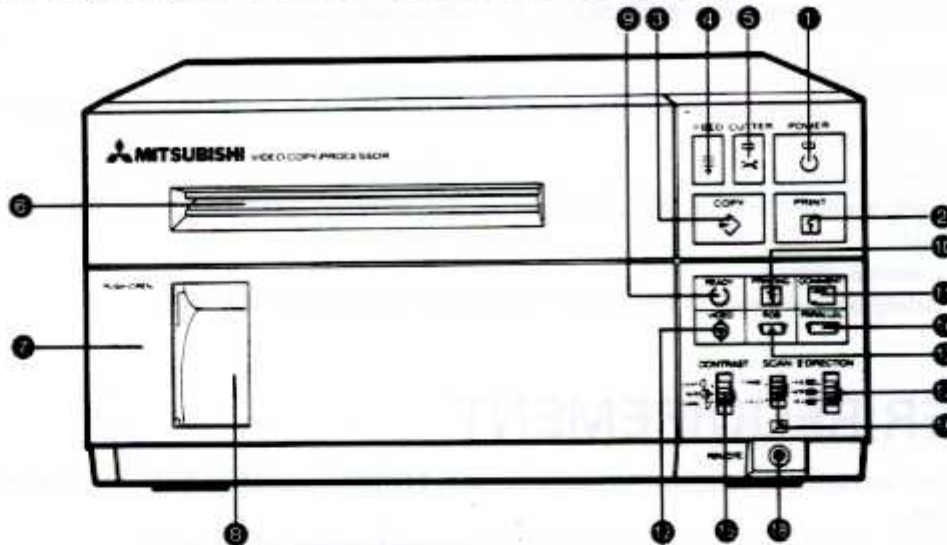

- 1 POWER INDICATOR/POWER SWITCH**
The green lamp lights when the MAINS switch on the rear panel is ON. When POWER INDICATOR lights, you can turn the power ON or OFF by pressing POWER button.
- 2 PRINT BUTTON**
Press the PRINT button to print the picture on the monitor screen.
- 3 COPY BUTTON**
Press the COPY button for additional copies of the print.
- 4 FEED BUTTON**
Press the FEED button to feed the paper constantly.
- 5 CUT BUTTON/AUTO-CUT INDICATOR**
Press the CUT button to cut the paper. After setting the paper, be sure to cut the paper by the CUT button. (See page 23). The green lamp lights to indicate the Auto-cut state. Auto-cut state is set by MODE 2 selector.
- 6 EXIT SLOT**
Printed paper will come out through this slot.
- 7 DOOR**
Open this door to set and replace the paper, or to use buttons 19-23
- 8 PRINT PAPER WINDOW**
You can confirm the amount of paper remaining through this window.
- 9 READY INDICATOR**
Light to Indicate that the VCP is ready to print.
- 10 PRINTING INDICATOR**
This blinks during printing. It lights to Indicate that the buzzer is set by the BUZZER button.
- 11 COMMENT INDICATOR**
Light to indicate that the predefined optional comment will be printed in the margins of the printing image. It's set by COMMENT button 20 inside the front door.

12 VIDEO INDICATOR

Light to indicate that VIDEO Input terminal 25 is selected by MODE 2 selector on the rear panel.

13 RGB INDICATOR

Light to indicate that RGB Input terminal 10 is selected by MODE 2 selector on the rear panel.

14 PARALLEL INDICATOR

PARALLEL INDICATOR lights when the input signal is set to PARALLEL. While this set is receiving the parallel data from external equipment, this indicator blinks.

15 CONTRAST SELECTOR

You can select the contrast of the print in three levels. (See page 19).

16 SCAN SELECTOR

In normal cases, set it at the FRAME position. The FRAME position captures a full image (two field images). Use FIELD mode to print quick action scenes. (See page 19)

17 DIRECTION SELECTOR

Set the DIRECTION selector to the NORmal position for normal direction print or copy. Set the DIRECTION selector to the REVerse or SIDE position for upside-down or side print or copy. (See page 19).

18 REMOTE TERMINAL

The wired remote control is connected here.
There is another terminal on the rear panel.

INSIDE PANEL CONTROLS — LOCATION AND DESCRIPTION

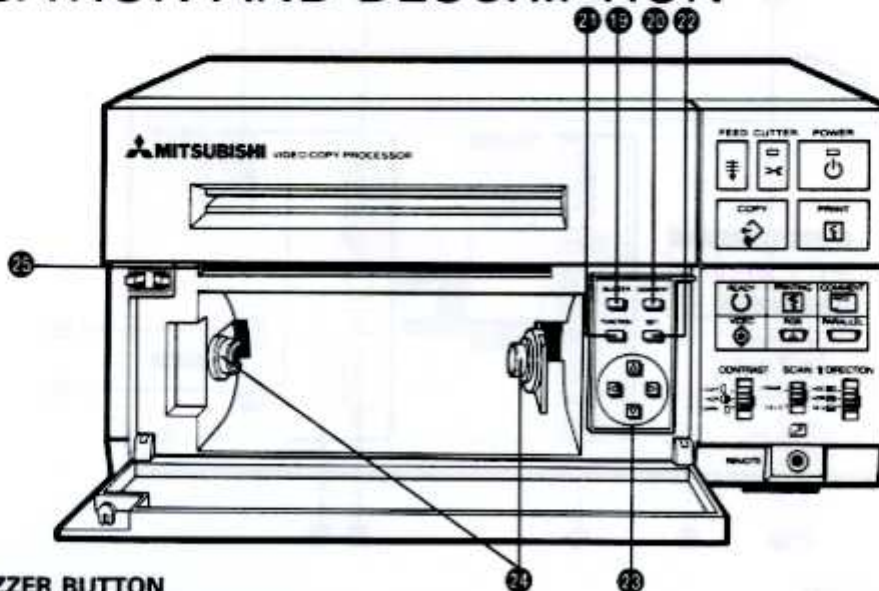

19 BUZZER BUTTON

The buzzer beeps at the beginning and ending of printing under the condition this function is switched ON. The printing indicator lights when this function is switched ON. Press to select buzzer ON/OFF.

20 COMMENT BUTTON

Push the COMMENT button to turn ON/OFF. Under the ON condition, predefined optional comments will be printed in the margins of the printing image.

21 FUNCTION BUTTON

This button selects three kind of menus,

- 1) Setting the picture quality.
(B-LEV, W-LEV etc) page 30~31
- 2) Setting the size and position of picture.
(H-WID, H-RES etc) page 32~37
- 3) Setting the comment page 38, 39

22 SET BUTTON

Set the comment and each value selected with **21** FUNCTION button and **23** SHIFT button to the memory by pressing SET button.

23 SHIFT BUTTONS

You can change the value of the menu selected with **21** FUNCTION button and by the SHIFT button.

24 PAPER HOLDER

Install the paper roll by inserting it into this holder. (See page 9).

25 ENTRANCE SLOT

New paper is inserted into this slot.

REAR PANEL TERMINOLOGY AND DESCRIPTION

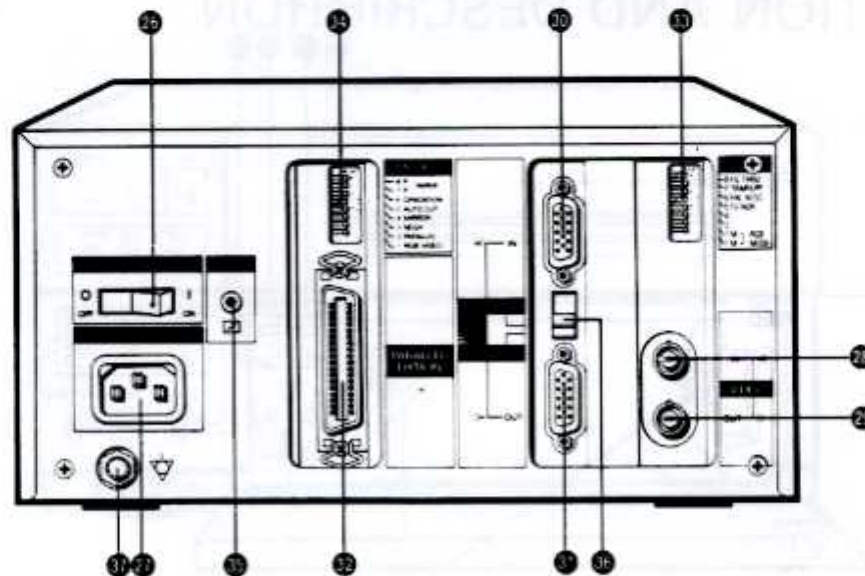

26 MAINS SWITCH

Turn the main power ON and OFF.

27 MAIN INLET

Power cord is connected here. Be sure to connect the attached cord.

28 VIDEO INPUT TERMINAL

The VIDEO INput terminal (BNC Type Receptacle) is used for the composite video signal from a TV, VCR Video Disc Player, Computer, Measuring Instrument.

29 VIDEO OUTPUT TERMINAL

Connect the VIDEO OUTput TERMINAL to the video input terminal of the monitor.

30 RGB INPUT TERMINAL

The RGB INput terminal (15 pin Connector) is used for RGB TTL or ANALOG video signals from a computer or other equipment.

31 RGB OUTPUT TERMINAL

Connect the RGB OUTput terminal to the RGB INput terminal of the monitor.

32 PARALLEL DATA INTERFACE TERMINAL (CENTRONICS® STANDARD)

The PARALLEL DATA INTERface terminal (36 pin connector) is used for the parallel data signals from the personal computer.

33 MODE 1 SELECTOR

MODE 1 selector (8 bit DIP-SW) is a group of the following selectors.

- RGB mode selector (bit 1, 2)
- Sync mode selector (bit 5)
- Video Filter selector (bit 6, 7, 8)

* Bit 3 and 4 are not in use.

34 MODE 2 SELECTOR

MODE 2 selector (8 bit DIP-SW) is a group of the following selectors.

- RGB/VIDEO selector (bit 1)
- PARALLEL data mode selector (bit 2)
- NEGA/posi selector (bit 3)
- MIRROR selector (bit 4)
- AUTO CUT function selector (bit 5)
- GRADATION selector (bit 6)
- PAPER selector (bit 7, 8)

35 REMOTE CONNECTOR

The wired remote control is connected here. There is another remote terminal on the front panel.

36 ANALOG/TTL SELECTOR

Select ANALOG or TTL video signal from RGB input connector **30** and output connector **31**. The pin assignment of both connectors is different in each mode. Refer to next section.

37 POTENTIAL EQUALIZATION CONNECTOR

This is used to equalize the potential of the equipment connected to this unit.

In medical rooms, when CF-type equipment* are connected, it is necessary to equalize the potential of both units.

For details, refer to the installation instruction of the equipment to be connected.

*** TYPE CF EQUIPMENT**

Class I or II EQUIPMENT or EQUIPMENT with an INTERNAL ELECTRICAL POWER SOURCE, providing a high degree of protection against electric shock particularly regarding allowable LEAKAGE CURRENTS, and having an F-TYPE ISOLATED (FLOATING) APPLIED PART. TYPE CF EQUIPMENT is primarily intended for DIRECT CARDIAC APPLICATION.

HOW TO INSTALL THE PAPER

One roll of thermal paper is provided in the carton box.

The thermal-head should be cleaned with the cleaning-sheet once for every 10 rolls for thermal paper. (Please refer to cleaning sheet handling instructions, page 28.)

Humidity, finger print, dust, etc. on the high density paper may deteriorate the printing quality or cause a noise at printing.

- A) Take care to keep away the high density paper from the occasion of being exposed to a finger print, dust, humidity, etc.
- B) A finger print or dust adheres to the high density paper surface when the paper is loaded. So load the paper as follows.

TURN ON THE MAIN SWITCH AT THE REAR PANEL

1 TURN THE POWER SOURCE ON AND OPEN THE DOOR

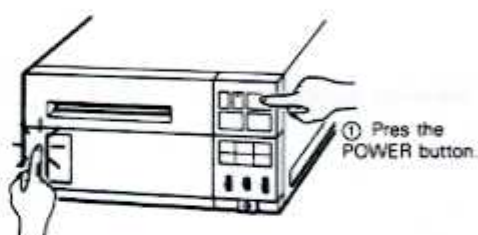

- ② Press on the upper left part of the panel. The door will open.

2 SET THE PAPER

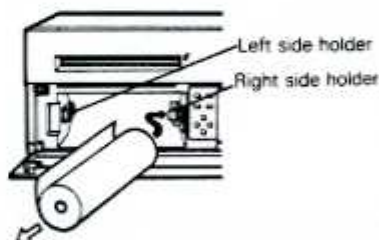

- ① Insert the roll of the paper onto the right side holder.
- ② As you push the roll to the right, fit the other side of the roll onto the left holder. Insert the other side of the roll onto the left side holder pushing the roller to the right.

Note: The print side of the paper is rolled to the outside. Make sure the paper is installed as shown in the figure.

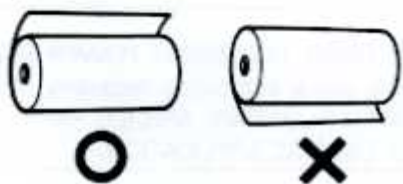

3 INSERT THE PAPER

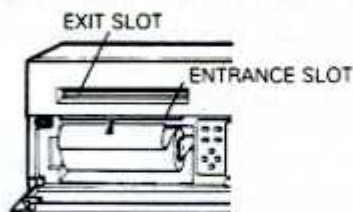

- ① Insert the end of the paper into the entrance slot. (See page 10, cautions on inserting paper)
- ② Upon inserting the paper, the paper will advance automatically. In case the paper does not advance automatically, press the feed button to insert the paper.

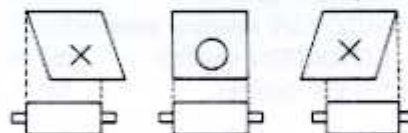

- ③ When the paper is obliquely ejected from the paper exit, adjust so that the paper is parallel at the paper inlet and exit.

4 DRAW OUT THE PAPER

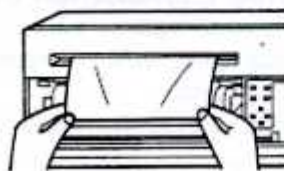

- ① Draw out gradually the part (approx. 30cm) touched by hand from the EXIT SLOT.

Note: Draw out the paper by hand without pressing the FEED button.

5 CUT THE PAPER

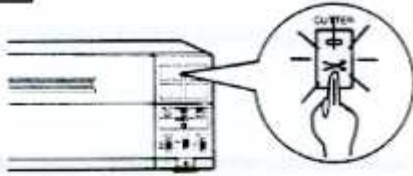

- ① Cut the paper by pressing the CUTTER button on the front panel.

When the cut button is turned on, the ready lamp lights and printing and copying is possible.

- Automatic paper cutting is also possible. For details, refer to page 23.

CAUTIONS ON INSERTING PAPER

- KEEP THE FOLLOWING POINTS TO PREVENT THE PAPER BEING JAMMED ON INSERTION.

A. INSERT IN A STRAIGHT LINE

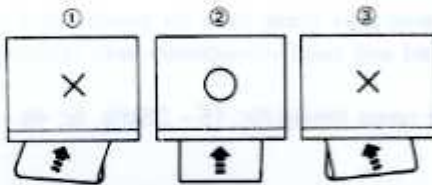

- When paper is inserted into the entrance slot the paper (as shown in ② of the left figure) should be parallel with the sides of the unit. Inserting the paper obliquely as shown in the figures ① · ③ may cause jamming.

B. TIP END SHOULD BE AT RIGHT ANGLES TO THE SIDES

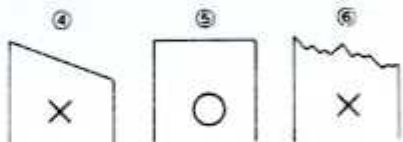

- The print paper should be cut square to the direction of paper feed as shown in the figure ⑤. Paper jamming may occur easily when the tip end is oblique or irregular - as shown in the figure ④ or ⑥.

C. AVOID USING WRINKLED OR PLEATED PAPER



- Do not insert pleated, wrinkled, or soiled paper.

D. CHECK TO SEE IF THE PAPER IS PARALLEL

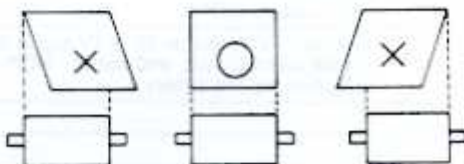

- Printing while the paper is not parallel with the roller may cause the paper edge to touch the wall, thus resulting in wrinkled paper.

CONNECTION EXAMPLES

The Video Copy processor can be connected to a wide variety of imaging devices with a variety of signal types.

- **Composite Video Signal:**

A composite video signal can be connected to the VIDEO INput/OUTput terminals (BNC-type). Most consumer and industrial video imaging products such as TV's VCR's Video Disc players, Medical Imaging Equipment, Security Monitoring Devices, some Measuring Instruments and personal computers have the composite video input and/or output.

Not only Television standard (PAL/NTSC/SECAM) but also the signals of wide range timing (fh: 15 – 35kHz, fv: 45 – 80Hz) are available.

- **RGB Analog Signal:**

A RGB Analog video signal can be connected to the RGB Input/Output terminals (15 pin-Connector) with RGB ANALOG/TTL Selector at ANALOG position.

A Personal computer image can be reproduced in 64-level grey scale, ideal for speedy hard copy of graphics. IBM® MCGA/VGA can be easily connected and used immediately with an optional cable. Not only IBM® standard, but also the signals of a wide range timing (fh: 15 – 35kHz, fv: 45 – 80Hz) are available.

- **RGB TTL Signal:**

A RGB TTL video signal can be connected to the RGB Input/Output terminals (15 pin-Connector) with RGB ANALOG/TTL Selector at TTL position.

A Personal computer image can be reproduced in 16-level grey scale, ideal for speedy hard copy of graphics. IBM® EGA/CGA/MDA can be easily connected and used immediately with optional adaptor cables.

Not only IBM® standard, but also the signals of a wide range timing (fh: 15 – 35kHz, fv: 45 – 80Hz) are available.

- **Parallel Data Interface (Centronics® Standard)**

The Parallel Data signals can be connected to Parallel Data Interface Terminal. Most functions operate from host computer via this interface. Refer to next section.

1. COMPOSITE VIDEO SIGNAL

A. VIDEO COPY PROCESSOR + TV

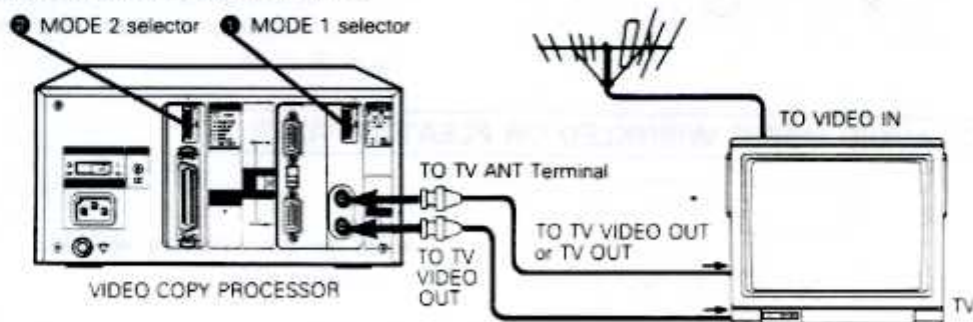

SETTING

① MODE 1 Selector

OFF position

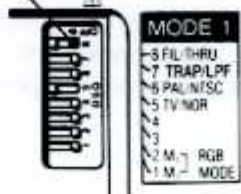

No.8 FIL/THRU	FIL position (ON)
No.7 TRAP/LPF	TRAP position (ON)
No.6 PAL/NTSC	PAL position (ON)
No.5 TV/NOR	Set to "TV" position for a TV signal of weak electric field, and set to "NOR" position for the others.
No.4	
No.3	
No.2 M ₁ RGB	Unrelated to VIDEO SIGNAL.
No.1 M ₂ MODE	

② MODE 2 selector

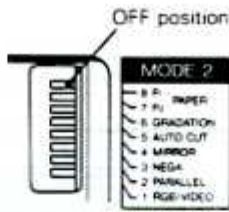

No.8 P ₁	PAPER	Make the setting according to the table on page 24.
No.7 P ₂	PAPER	Make the setting according to the table on page 24.
No.6 GRADATION		OFF
No.4 MIRROR		OFF
No.3 NEGA		OFF
No.2 PARALLEL		OFF
No.1 RGB/VIDEO		VIDEO position (OFF)

③ FIELD/FRAme Selector.....FRAME

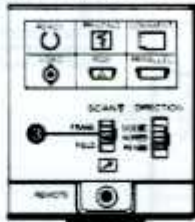

B. VIDEO COPY PROCESSOR + VCR + TV

a) TV with Video Input terminal

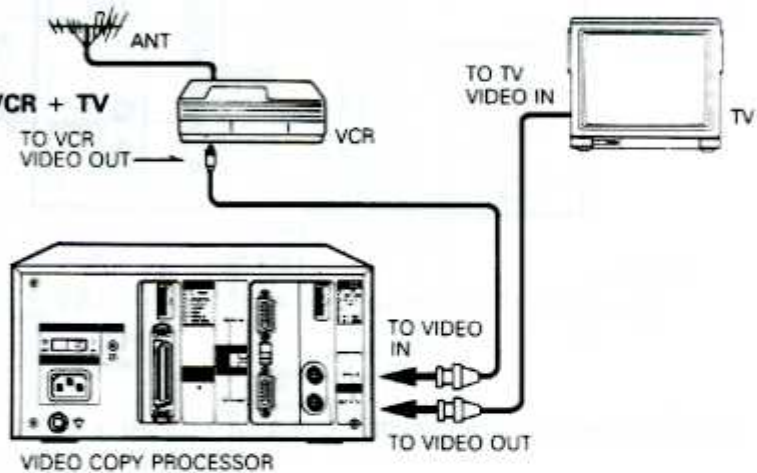

SETTING

① MODE 1 selector

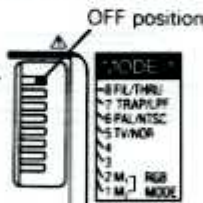

No.8 FIL/THRU		FIL position (ON)
No.7 TRAP/LPF		TRAP position (ON)
No.6 PAL/NTSC		PAL position (ON)
No.5 TV/NOR		Normally, set the switch "NOR" position. For noisy signal, set the switch "TV" position.
No.4		
No.3		
No.2 M ₁	RGB	
No.1 M ₂	MODE	Unrelated to VIDEO SIGNAL.

② MODE 2 selector

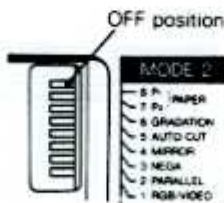

No.8 P ₁	PAPER	Make the setting according to the table on page 24.
No.7 P ₂	PAPER	Make the setting according to the table on page 24.
No.6 GRADATION		OFF
No.4 MIRROR		OFF
No.3 NEGA		OFF
No.2 PARALLEL		OFF
No.1 RGB/VIDEO		VIDEO position (OFF)

③ FIELD/FRAme selector.....FRAME

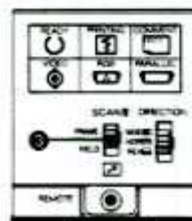

b) TV without Video Input Terminal

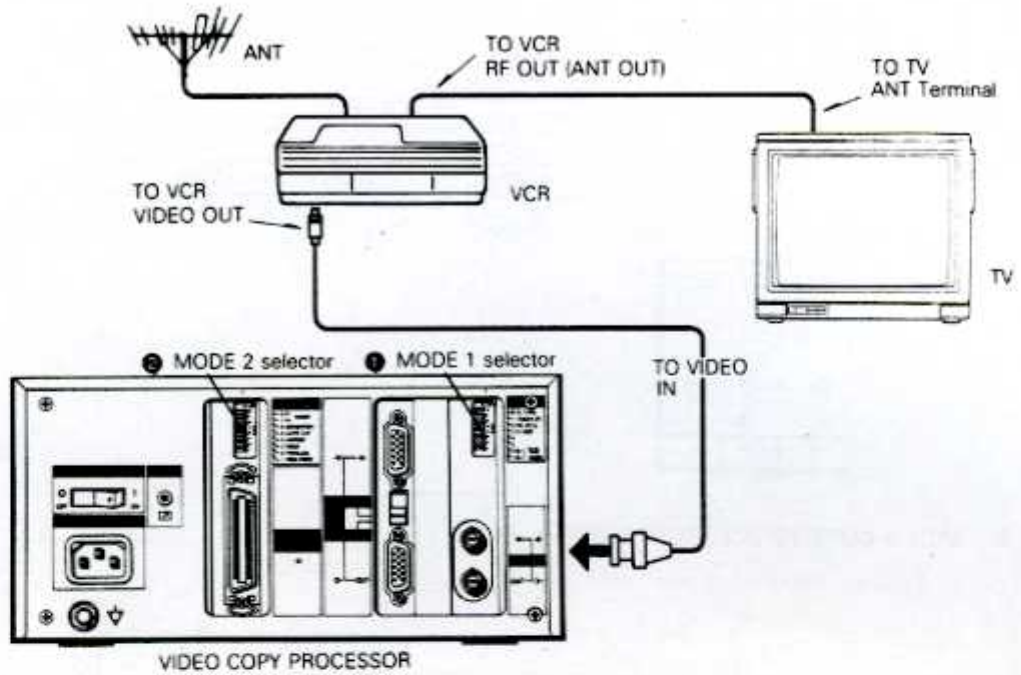

SETTING

For setting of various switches, refer to "VIDEO COPY PROCESSOR + TV" section. (Pages 11~12)

C. VIDEO COPY PROCESSOR + CAMERA + (VCR) + TV

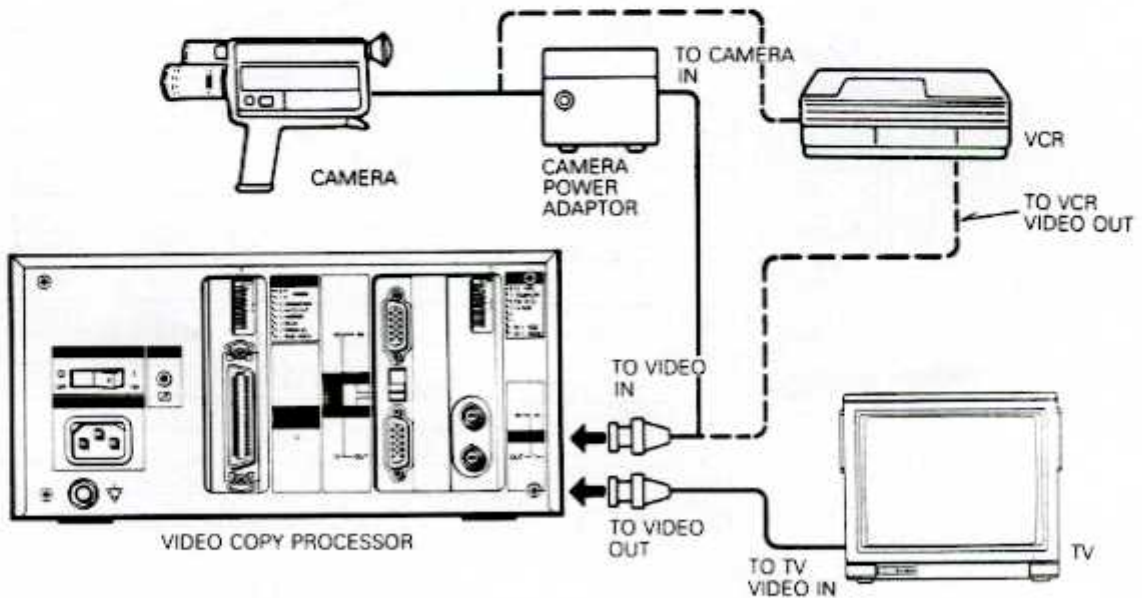

- a) When using a VCR, connect the video signal from the camera directly to the Camera in of the VCR.
- b) If a VCR is not used, connect the Video out from the Camera power adaptor to the Video in of the Video Copy Processor.

SETTING

For setting of various-switches, refer to "VIDEO COPY PROCESSOR + VCR + TV - TV with Video Input terminal" (Page 12)

D. VIDEO COPY PROCESSOR+ MEDICAL IMAGING EQUIPMENT OR INDUSTRIAL MEASURING INSTRUMENT

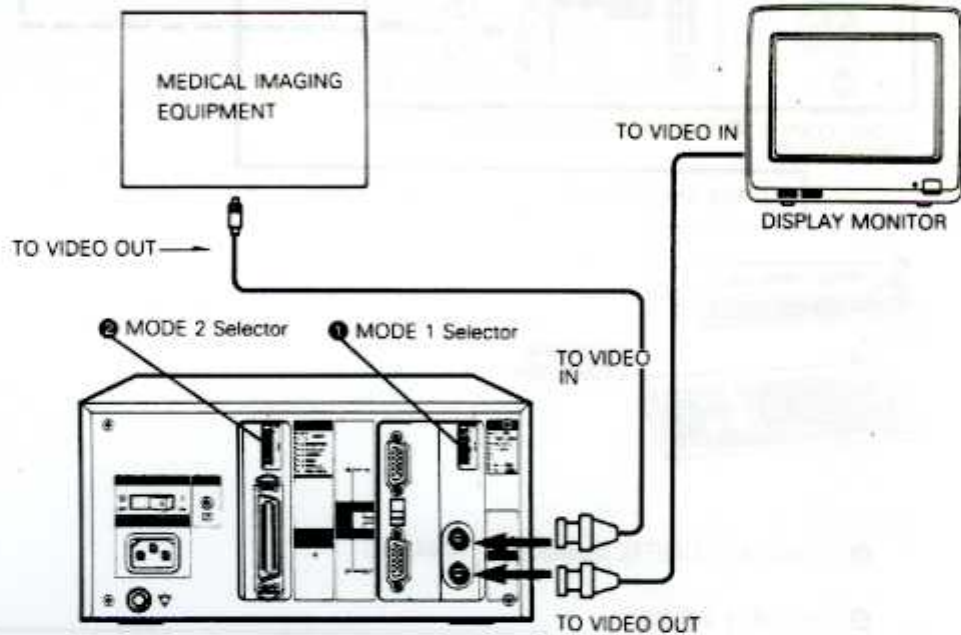

CONNECT THE POTENTIAL EQUALIZATION CONNECTOR

1. MODE 1 Selector
OFF position



No.8 FIL/THRU	THRU position (OFF)
No.7 TRAP/LPF	
No.6 PAL/NTSC	
No.5 TV/NOR	NOR position (OFF)
No.4 —	—
No.3 —	—
No.2 M ₁ RGB	Unrelated to VIDEO SIGNAL.
No.1 M ₂ MODE	

2. MODE 2 Selector

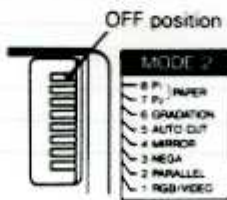

No.8 P ₁ PAPER	Make the setting according to the table on page 24.
No.7 P ₂	
No.6 GRADATION	OFF
No.4 MIRROR	OFF
No.3 NEGA	OFF
No.2 PARALLEL	OFF
No.1 RGB/VIDEO	VIDEO position (OFF)

3. FIELD/FRAME Selector.....FRAME

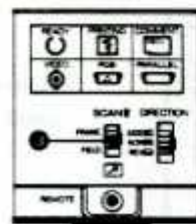

2. RGB ANALOG SIGNAL

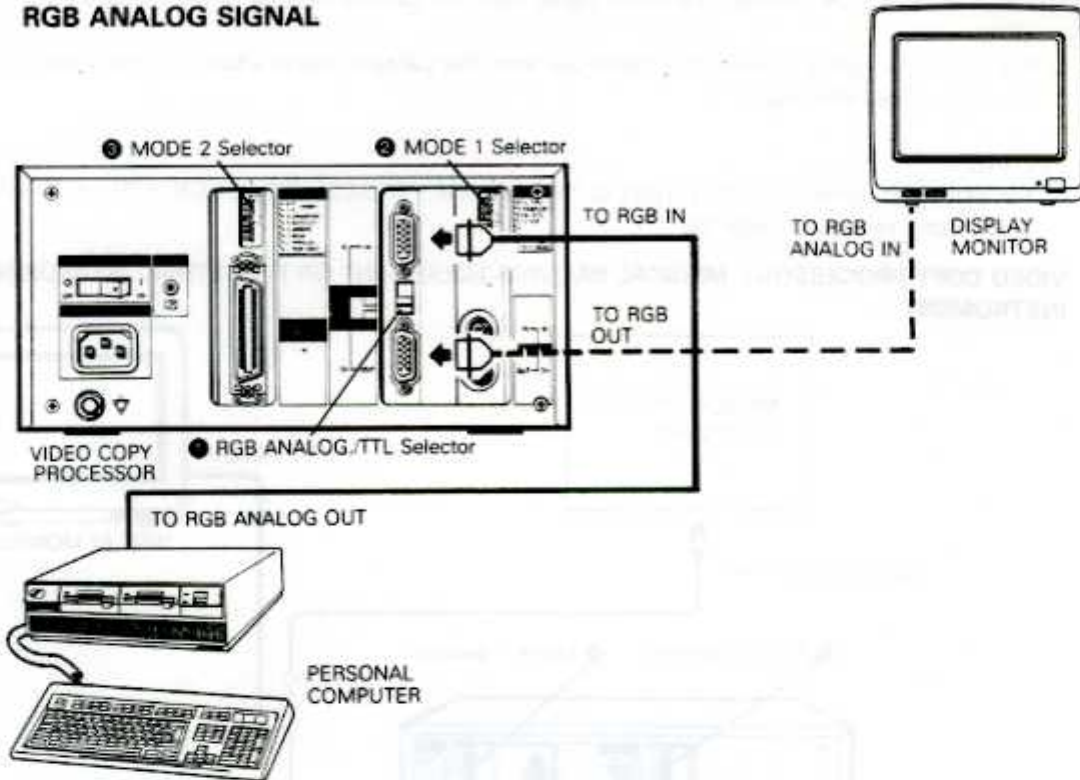

SETTING

- 1 RGB ANALOG/TTL SelectorANALOG
- 2 MODE 1 Selector

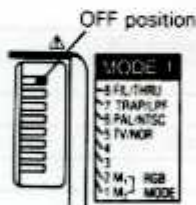

No.8 FIL/THRU	Invalid
No.5 TV/NOR	
No.4	
No.3	
No.2 M ₁ RGB	OFF: when using IBM® PS/2 ON : when using other computers
No.1 M ₂ MODE	Irrelevant.

- 3 MODE 2 Selector

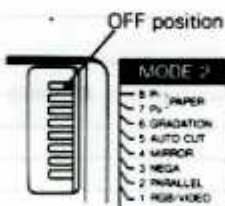

No.8 P ₁ PAPER	Make the setting according to the table on page 24.
No.7 P ₂	
No.6 GRADATION	OFF
No.4 MIRROR	OFF
No.3 NEGA	OFF
No.2 PARALLEL	OFF
No.1 RGB/VIDEO	RGB position (ON)

- 4 FIELD/FRAME SelectorFRAME

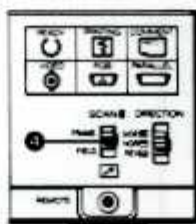

* When computers other than IBM® PS/2 are used, operation of FUNCTION STEP2 would be necessary. Refer to the next chapter (Page 37).

3. RGB TTL SIGNAL

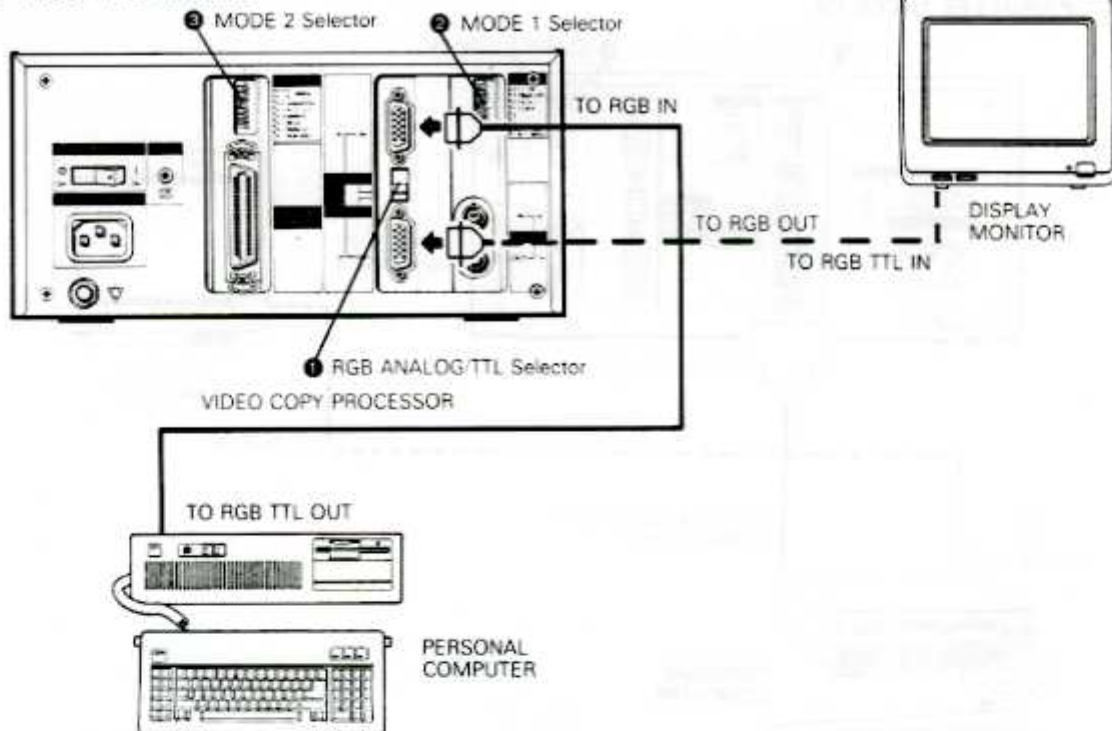

SETTING

① RGB ANALOG/TTL SelectorTTL

② MODE 1 Selector

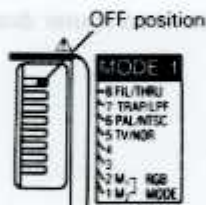

No.8	FIL/THRU	Invalid
No.5	TV/NOR	
No.4	—	—
No.3	—	—
No.2	M ₁ RGB	M ₁ OFF When using IBM® MDA
	M ₂ MODE	M ₂ OFF
No.1	M ₁ MODE	M ₁ OFF When using IBM® EGA/CGA
	M ₂ MODE	M ₂ ON
		M ₁ ON When using other computers

③ MODE 2 Selector

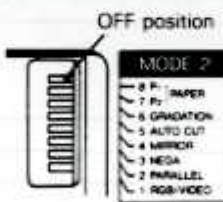

No.8	P ₁ PAPER	Make the setting according to the table on page 24.
No.7	P ₂ PAPER	
No.6	GRADATION	OFF
No.4	MIRROR	OFF
No.3	NEGA	OFF
No.2	PARALLEL	OFF
No.1	RGB/VIDEO	RGB position (ON)

④ FIELD/FRAME Selector.....FRAME

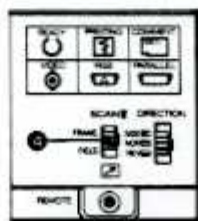

- When computers other than IBM® EGA/CGA/MDA are used, operation of FUNCTION STEP2 would be necessary. Refer to the next chapter (Pages 34~35).
- The RGB indicator is lit on the front panel while the RGB signal is being applied.

4. PARALLEL DATA IN

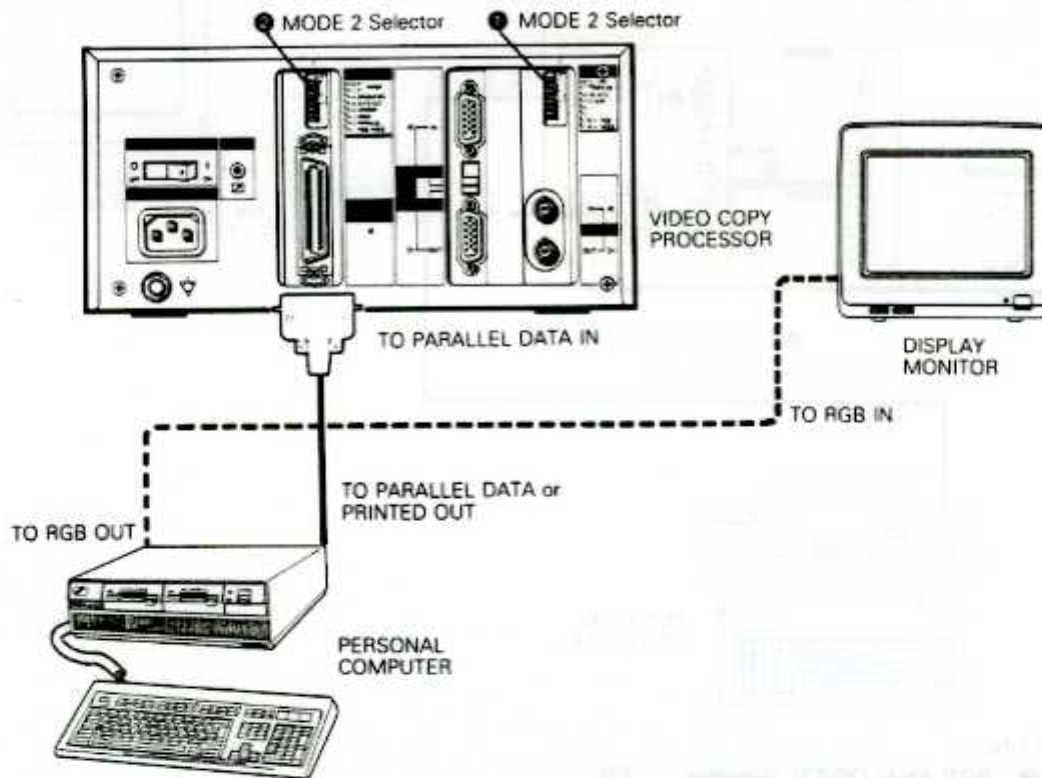

- Connect the parallel data output signal from the personal computer to PARALLEL DATA IN of the Video Copy Processor.
- If a display monitor is used, connect the RGB signal from the personal computer directly to the RGB in of the display monitor.

SETTING

- MODE 1 SelectorRegardless of PARALLEL
- MODE 2

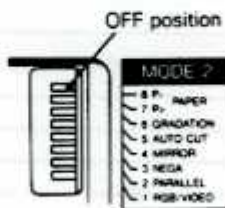

No.8 P ₁	PAPER	Make the setting according to the table on page 23.
No.7 P ₂	PAPER	
No.6 GRADATION		Invalid
No.4 MIRROR		
No.3 NEGA		
No.2 PARALLEL		ON position
No.1 RGB/VIDEO		Invalid

- In the parallel data input mode, it is possible to combine with each signal, Video, RGB-Analog or RGB-TTL. In this case, print out of each signal or changes of setting can be controlled from a personal computer. Refer to the "MULTI-USE CONTROL CODES" for details (Pages 43~50).

PRINTING METHOD

1. INPUT SIGNAL SELECTION

- Video, TTL and analog signals are selected via the Mode switch and ANALOG/TTL selectors on the rear panel.

Make sure that the setting for each is correct. (Refer to pages 11~17.)

TURN ON THE MAIN SWITCH AT THE REAR PANEL

1 TURN ON THE POWER

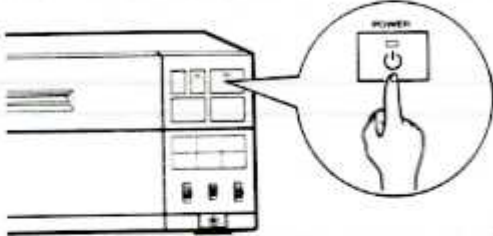

3 PRESS THE COPY BUTTON

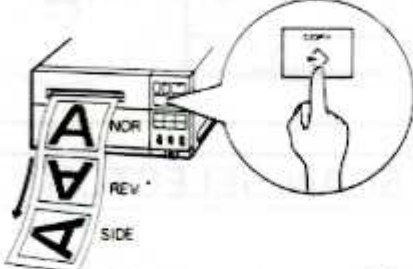

- Every time the COPY button is pressed, the last picture that has been printed will be printed out.

2 PRESS THE PRINT BUTTON

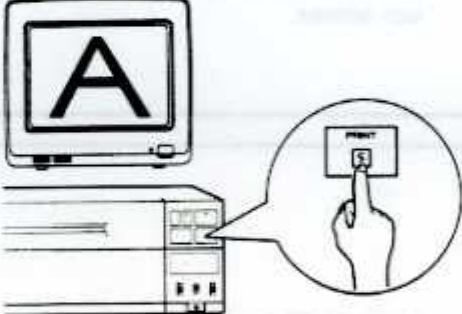

- If the picture desired to be printed appears on the monitor, press the PRINT button.

4 CUT THE PAPER

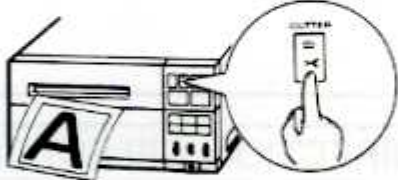

- Press the front panel's CUT button to cut the paper.
- Automatic paper cutting is also possible (See page 23).

- During printing, PRINTING indicator keeps on blinking.

OPERATION VIA REMOTE CONTROL

- Connect the wired remote control either to the REMOTE terminal on the front panel or the one on the rear panel.
- It is possible to print out by pressing the remote control button - similar functionwise to the PRINT button.

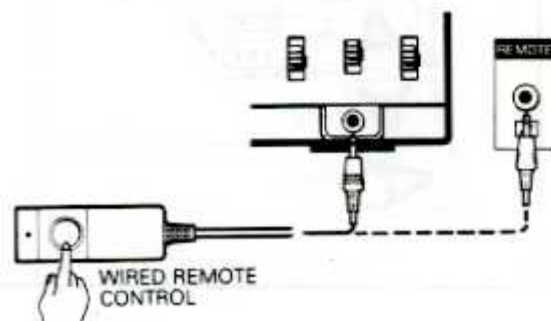

PICTURE ADJUSTMENT

CONTRAST SELECTOR

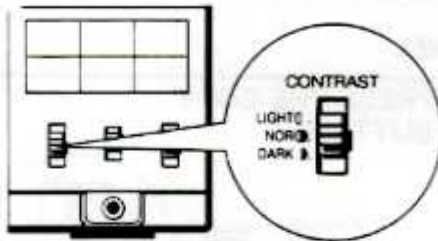

This set is equipped with a 3 step-contrast selector. Select the appropriate position.

- LIGHT:** Set this position to produce a lighter print.
- NORMAL:** Set this position to produce a normal print.
- DARK:** Set this position to produce a darker print.

SCAN SELECTOR

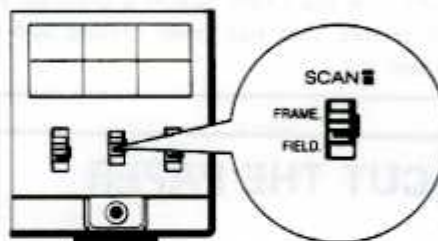

- FRAME:** In normal cases, set at the position of FRAME. The FRAME position captures a full image (two field images).
- FIELD:** The FIELD position captures one complete field or 1/2 vertical resolution. Use the FIELD mode to capture the next field while one field is already printing. Or use the FIELD mode to print the quick action scenes.

DIRECTION SELECTOR

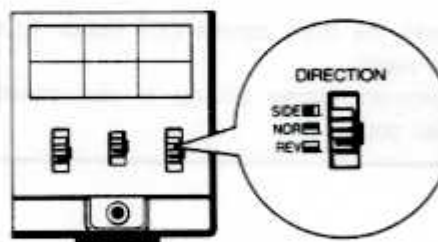

- SIDE:** In the "SIDE" position, the image is printed side-wise (rotated by 90°).
- NOR:** In the "NOR"mal position, the image orientation of the print is the same as the image as seen on the video display. That is, the print emerges with the bottom of the image first.
- REV:** In the "REV" position, the image is printed upside down. This position is useful when printing images occurring in sequence such as text from a personal computer or successive plays of a sporting event.

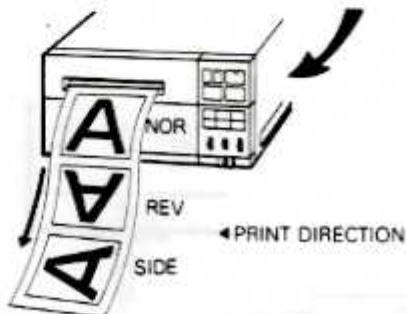

BUZZER FUNCTION

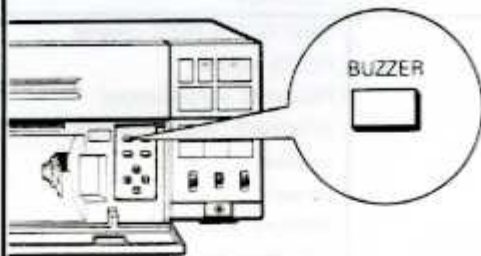

- If the BUZZER has been set to ON, the alarm will sound at the beginning and end of the printing process.
Press to change from ON to OFF.
In the "ON" state, the PRINTING indicator is lit.

PRINTING PRECAUTIONS

- When dark pictures are continuously printed, the internal overheat protection function may work to disable the printing.
(This function does not work for switches other than POWER and CUT.)
In this case, wait for several seconds until the unit has cooled down.
- It is possible to make a black line - depending on the type of video signal sent to the Video Copy Processor and the nature of the printed out picture.
- During printing or copying, if the paper is pulled or pressed, the paper may jam.
Be sure not to touch the paper.
- If the rear panel's INPUT switch has been set to "PARALLEL", it will not be possible to print out or copy via the front panel's button or remote control.
- Other reasons for incapability of print out are explained on pages 25 to 27.

MODE SWITCH FUNCTIONS

1. MODE 1

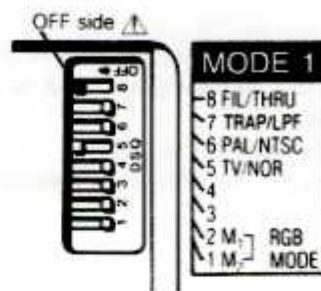

BIT	ABB	FUNCTION
⑧	FIL/THRU	TRAP FILTER/THRU selector
⑦	TRAP/LPF	FILTER selector
⑥	PAL/NTSC	PAL/NTSC signal selector
⑤	TV/NOR	SYNCHRO CIRCUIT selector
④	—	Unused
③	—	Unused
②	M ₁ RGB MODE	MANUAL/AUTO selector
①	M ₂	COLOR/MONO selector

SWITCH FUNCTIONS

① M₂ ② M₁

- The input mode setting of the RGB/TTL analog signal can be made by setting bits ① and ②.
- Set the specifications of the signal fed from the connected device as in the table hereunder.

Computer/Graphic board	ANALOG/TTL Selector	M ₁	M ₂
IBM® Monochrome Display/Adapter	TTL	OFF	OFF
IBM® EGA/CGA	TTL	OFF	ON
IBM® MCGA/VGA (PS/2)	ANALOG	OFF	OFF
IBM PGC or Apple® MACII	ANALOG	ON	—
None of above	Confirm the signal type and select ANALOG or TTL	—	—

⑤ MODE SWITCH FUNCTIONS

Set the Synchro circuit mode selection to "NOR" position for normal use. If the electric signal is weak or noise is significant, set it to "TV" position. When VTR is to be used, set it to "TV".

MODE	FUNCTION
NOR	f _H : 15 ~ 35kHz f _V : 45 ~ 80Hz
TV	f _H : 15.75kHz (vicinity only) Conformable to withstand noise, weak broadcasting, and VTR signals.

⑥ PAL/NTSC

Select PAL or NTSC, in accordance with the input signal.

⑦ TRAP/COMB ⑧ FIL/THRU

A filter can be selected via the settings of bits. ⑥, ⑦ and ⑧.

MODE 1 SWITCH FUNCTION			SELECTION
8	7	6	
THRU	—	—	Filter will not act.
FIL	LPF	—	LOW PASS Filter
FIL	TRAP	PAL	PAL (4.43MHz) TRAP ON
FIL	TRAP	NTSC	NTSC (3.58MHz) TRAP ON

- However, if "DIRECT ON" has been selected at the menu of STEP 1, this setting will be rendered ineffective, and the filter cannot be used.

2. MODE 2

OFF side

MODE 2

- 8 P₁ PAPER
- 7 P₂ PAPER
- 6 GRADATION
- 5 AUTO CUT
- 4 MIRROR
- 3 NEGA
- 2 PARALLEL
- 1 RGB/VIDEO

BIT	ABB.	FUNCTION
⑧	P ₁ PAPER	Paper selection
⑦	P ₂ PAPER	Paper selection
⑥	GRADATION	Gradation ON/OFF
⑤	AUTO CUT	Automatic cutting ON/OFF
④	MIRROR	Mirror printing ON/OFF
③	NEGA	Negative/Positive printing selection
②	PARALLEL	Parallel Input/Composite Video, RGB selection
①	RGB/VIDEO	Composite Video, RGB input selection

SWITCHES FUNCTIONS

① RGB/VIDEO ② PARALLEL

- The input signal, whether Composite Video, RGB Analog or Parallel Data Interphase, is determined by setting Bits ① and ②.

INPUT SIGNAL	①	②
RGB (TTL ANALOG)	RGB side (ON)	PARALLEL OFF side
Composite video	VIDEO side (OFF)	PARALLEL OFF side
Parallel	—	PARALLEL ON side

③ NEGA

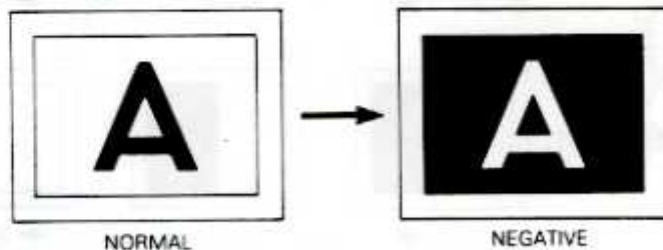

- If it is set at ON side, black/white print-out in reverse to the picture displayed can be made.
- Keep it set at OFF side to carry out normal picture print outs.

④ MIRROR

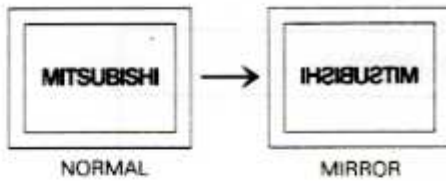

- If it is kept set at ON side, mirror-like print-out - similar to that shown in the left figure - can be made.
- Keep it set at OFF side to carry out normal picture print-outs.

⑤ AUTO CUT

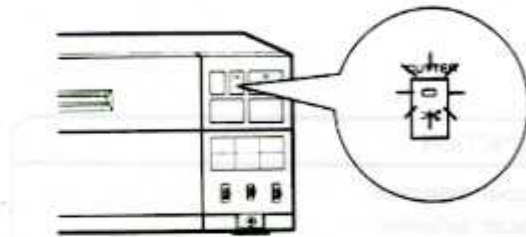

- If it is kept set at ON, the paper will be cut after printing has ended. When it is set at ON, the front panel's green CUT button lights.
- If it is kept at OFF side, automatic cutting will not be possible. To cut the thermo paper, press CUT button located on the front panel.

⑥ GRADATION

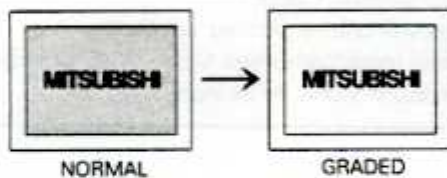

- If it is kept set at ON side, graded print-out (back/white with no mid-tones) can be made.
- For normal print-outs, keep it set at OFF side.

- For composite video and RGB analog signals, if the B-LEV digital values are changed, it would be possible to change the gradation standard level.

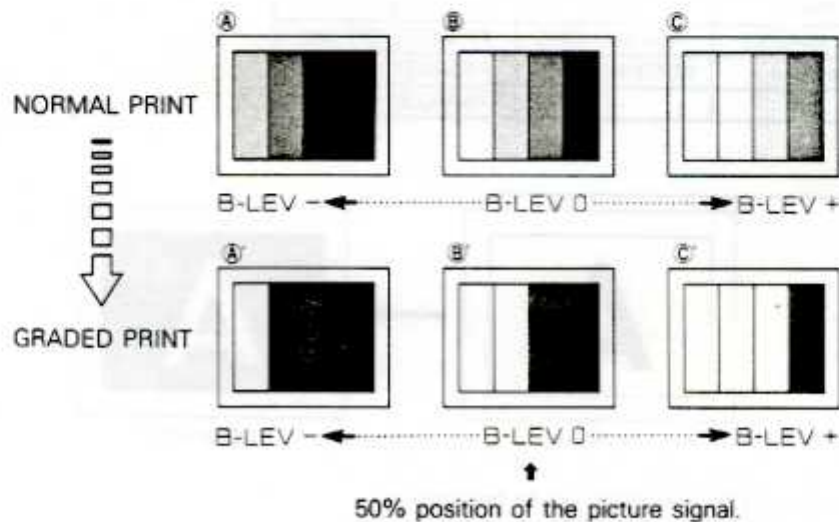

- For RGB (TTL), black level will be defined when the input G signal is at H (high) and the WHITE level is at L (low).

⑦ P₂ ⑧ P₁ PAPER

- Set in accordance with the type of registration paper being used.

SWITCH		TYPE OF PAPER
P1	P2	
OFF	OFF	K-61S
ON	OFF	K-60N
ON	ON	K-65H/K-65HM

WHEN PRINTING IS NOT POSSIBLE

SYMPTOM 1. IN CASE OF PAPER JAMS

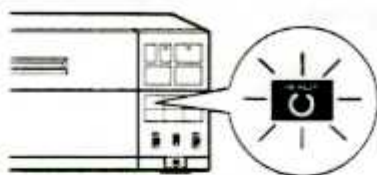

- If the buzzer sounds and the READY indicator blinks after the PRINT or COPY button is pressed, the paper is jammed. In this case, stop pressing PRINT, COPY or FEED button, and follow the procedures.

A. OVERCOMING PAPER JAM PROCEDURES

- IF THE PAPER IS JAMMED, FOLLOW THE PROCEDURES HEREUNDER TO REMOVE THE PAPER.

1 TURN OFF THE POWER OPEN THE DOOR

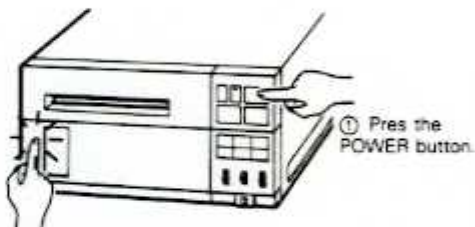

- ② Press on the upper left part of the panel. The door will open.

3 CUT THE PAPER

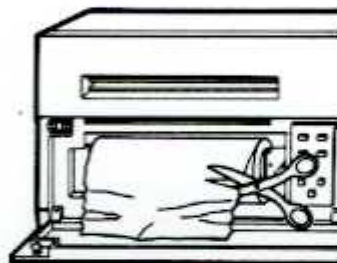

- Cut off the damaged portion of the paper.

2 REMOVE THE PAPER

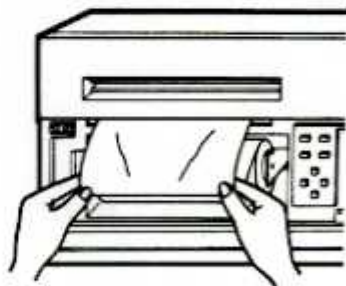

- Pull or remove the thermal paper in a straight direction from the paper roll insertion inlet side.
- At that time, if the power source has not been turned off, AUTO-LOADING process will be activated and the paper will be pulled back.

4 RE-FIT THE PAPER

After completing the above steps, reset the paper in accordance with the instructions of "HOW TO INSTALL THE PAPER" on pages 9~10.

B. CAUSES OF PAPER JAMS

- Note the elements stated hereunder can easily produce paper jammings.
 - ① If the paper is pulled out or pressed during the printing or copying process.
 - ② If the paper has been inserted in an oblique direction.
 - ③ If wrinkled or pleated paper has been inserted.

SYMPTOM 2. IN CASE OF CONDENSATION

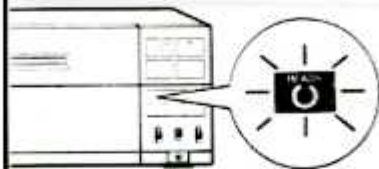

- When the READY indicator blinks, the unit may be subject to dew formation. In this case, the indicator keeps blinking and no paper can be set.

A. OVERCOMING CONDENSATION

1 OPEN THE DOOR

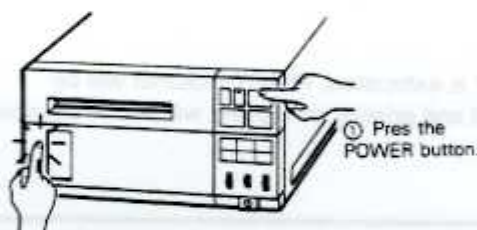

- ② Press on the upper left part of the panel. The door will open.

3 IMPROVE VENTILATION

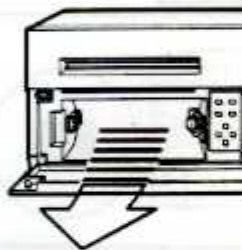

When dew has formed, wait until the unit is dry.

2 REMOVE THE PAPER



4 RE-FIT THE PAPER



If READY indicator stops flashing, re-fit the paper in accordance with the "HOW TO INSTALL THE PAPER" instructions on Pages 9~10.

B. CAUSES OF DEW CONDENSATION

Dew forms in cold regions, when low ambient temperature is sharply raised by heating. In such a case, printing or copying is not possible.

SYMPTOM 3. IN CASE OF OVER-HEAT

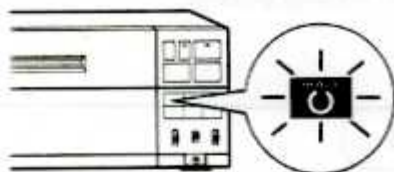

- When the READY indicator blinks and it is not possible to PRINT or COPY, the unit may be subject to over-heat. In this case, all front panel buttons except for the POWER button and CUT button will cease to function. Wait until blinking of the indicator stops.

A. OVERCOMING OVER-HEAT

In this case, all front-panel buttons-except for the POWER button and CUT button-will cease to function. Wait until blinking of the indicator stops.

B. CAUSES OF OVER-HEAT

When blackened pictures or frames have been printed in excess, the unit may over-heat.

SYMPTOM 4. WHEN PAPER IS EXHAUSTED

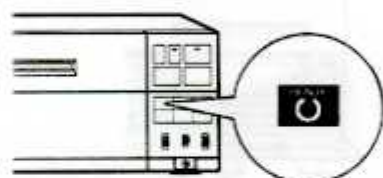

- When paper is exhausted, READY indicator will be extinguished and printing or copying will not be possible.

COUNTER MEASURE

Fit the new paper into the unit in accordance with the instructions in "HOW TO INSTALL THE PAPER" on pages 9~10.

OTHER CAUSES THE PARALLEL SWITCH HAS SET TO ON



- If the No.2 PARALLEL switch of the MODE 2 selector on the rear panel is turned ON, print or copy will not be possible.

OTHER CAUSES THE CUT SWITCH IS NOT PRESSED AFTER THE PAPER IS SET.

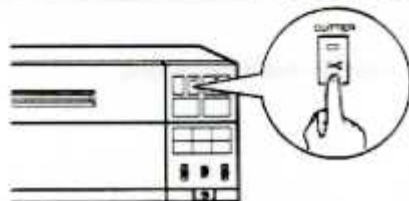





- If the CUT button is not pressed after the paper is set, the READY lamp is not lit and print or copy will not be possible.

CLEANING SHEET HANDLING INSTRUCTIONS

Cleaning procedure for The Video Copy Processor's Thermal Head

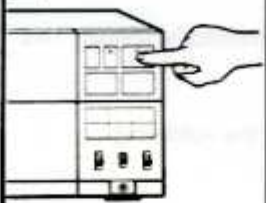
If dirt or dust particles adhere to the thermal head of the Video Copy Processor, the colored surface of the print-out may have rain-like patterns or vertical white lines.

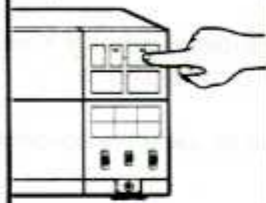
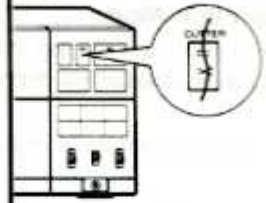
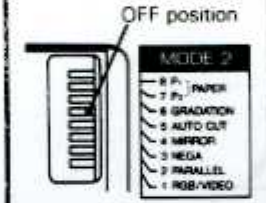
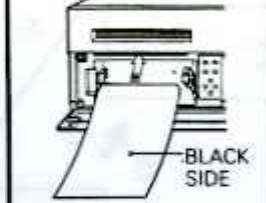
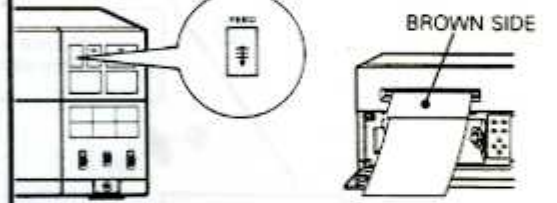
In such a case, use the accompanied Cleaning Sheet in accordance with the following procedure.

<p>1</p>  <p>TURN OFF THE POWER.</p>	<p>2</p>  <p>OPEN THE DOOR, AND PULL OUT THE THERMAL PAPER FROM THE ENTRANCE SLOT. REMOVE THE PAPER FROM THE UNIT.</p>	<p>3</p>  <p>TURN ON THE POWER.</p>	<p>4</p>  <p>MAKE SURE THE AUTO CUTTER'S SWITCH IS TURNED OFF AT THAT TIME. THE INDICATOR OF THE "CUT" BUTTON SHOULD BE OFF TOO.</p>
<p>5</p>  <p>WHEN THE INDICATOR IS LIT, TURN OFF THE NO.5 AUTO CUT SWITCH OF THE MODE 2 SELECTOR ON THE REAR PANEL.</p>	<p>6</p>  <p>INSERT THE END OF THE CLEANING SHEET INTO THE ENTRANCE SLOT. NOTE: MAKE SURE THE BLACK-COLORED SIDE IS FACING UP-WARD.</p>	<p>7</p>  <p>PRESS THE "FEED" BUTTON, AND ADVANCE THE CLEANING SHEET UNTIL ITS WIDTH IS EXITED TOTALLY. NOTE: IF THE SHEET DOES NOT ADVANCE UPON PRESSING "FEED" BUTTON, PULL IT OUT. RE-INSERT IT AS DEEP AS POSSIBLE.</p>	
<p>8</p>  <p>ALSO, IF THE CLEANING SHEET IS INSERTED AT A SLANT, IT WILL WRINKLE. TO AVOID SUCH DEFECTS, MAKE SURE TO INSERT THE SHEET AT A RIGHT ANGLE, TO THE ENTRANCE SLOT.</p>	<p>9</p>  <p>AFTER PASSING THE CLEANING SHEET 2~3 TIMES, RE-INSTALL THE PAPER AND PRINT OUT 2~3 SHEETS IN ORDER TO CHECK THE CLEANING EFFECT.</p>		

- If the No.2 PARALLEL switch of the MODE 2 selector on the rear panel is turned ON, (the PARALLEL indicator of the front panel will light), FEED button, switch or the like will not operate.
- If the cleaning sheet is damaged during use, correction of the damage would be necessary. Consult with the local distributor.
- Do not expose the cleaning sheet to direct sunlight. Store it in cold dark place.
- This cleaning sheet is for cleaning thermal heads. Do not use it for any other purpose. (Store in places not likely to be reached by children.)
- *Note that the cleaning sheet may dissolve or be destroyed by organic solvents (thinner, alcohol, etc.) acids, alkalines and similar agents.

CAUTION: If the cleaning sheet is used in excess, the thermal head may suffer ill effects. As an easy usage guideline, use the cleaning sheet once for every 10 rolls of paper.

USING THE SPECIAL FEATURES

— Function Mode Setting —

This unit complies with every kind of input signal. However, the setting values for each picture should be memorized as standard values. Further, adjustment in accordance with the input signal of the video device can be set and carried out by yourself. The set values will be memorized as USER's values - different from the standard values.

Function Mode

The picture will be set in accordance with the Function Mode displayed on the monitor's screen. This Mode is categorized from STEP 1 to STEP 3.

- Function Mode is changed by using the operation button in accordance with the following:

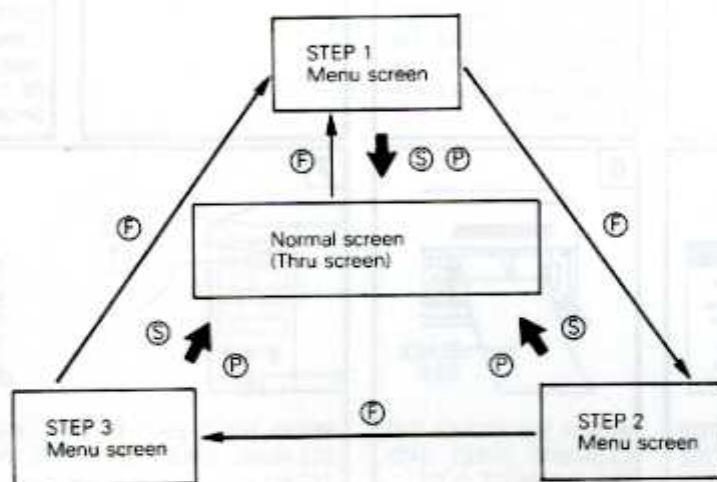

(F): Press the FUNCTION button.

(S): Press the SET button.

(P): Press the PRINT or COPY button.

Upon pressing it, setting is done automatically, and printing is carried out.

1. INPUT OF VIDEO SIGNAL

- Verify the setting of switches on pages 11 to 14 before entering the signal from the video equipment.
- Push and open the front door. The switches are found as shown in the drawing.

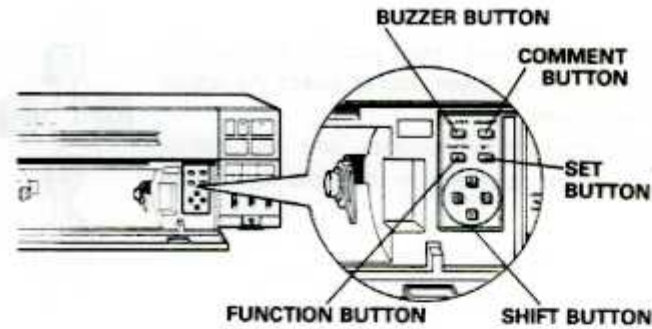

1-a. INPUT OF VIDEO SIGNALS OTHER THAN TV SIGNAL

The equipment is preset to permit the input of a TV signal. Make the following adjustments to input the other video signals.

- Set the selector No. 5 TV/NOR of MODE 1 to the OFF (NOR) position.

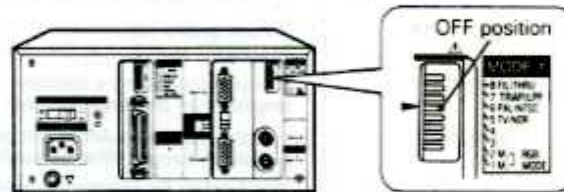

- Press the FUNCTION button twice, and press the SHIFT button located on the left. "USER" is selected on the screen of **STEP 2**, and a TV signal can be entered.

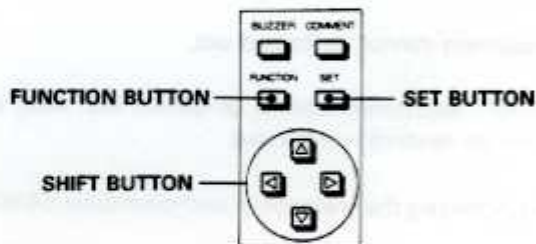

VIDEO	USER	STD
H-WID	770	770
H-TRC	0	0
H-RES	640	640
H-STR	42	42
V-LIN	625	625
V-STR	36	36
V-RES	580	580
H-SIZ	100	100
V-SIZ	75	75

STEP 2

- Press the SET button.

1-b. INPUT OF TV SIGNAL

STEP 1

- Press the FUNCTION button. The message shown on the right is displayed overlapped on the monitor screen. These are the displays for adjusting the picture black level, contrast and quality and for processing the input signal.



VIDEO	USER	STD
B-LEV	0	0
W-LEV	0	0
SHARP	0	0
AGC	OFF	OFF
DIRECT	OFF	OFF
DITHER	OFF	OFF

A USE IN A STANDARD PICTURE

A standard value of picture is preset in this unit.

- When a picture or a signal is not adjusted, press the right SHIFT button to set the cursor to "STD". The screen display is changed as shown on the right, and the standard value is selected.

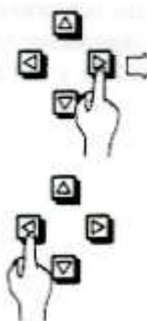

VIDEO	USER	STD
B-LEV		STD
W-LEV		
SHARP		
AGC		
DIRECT		
DITHER		

B ADJUSTMENT OF PICTURE

- To adjust a picture or a signal, press the left SHIFT button to move the cursor to "USER".

- 2) Use the up/down SHIFT buttons to move the cursor up and down and to select the adjustment items.
The adjustment contents and the setting ranges are as shown in the table hereunder.

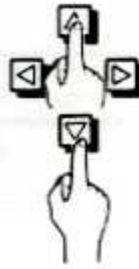

VIDEO	USER	STD
B-LEV	0	-3
W-LEV	0	+4
SHARP	0	+2
AGC	OFF	OFF
DIRECT	OFF	OFF
DITHER	OFF	OFF

Screen Display	Setting Range	Adjustment Contents
B-LEV	-25 ~ +25	Adjustment of the Black level for an analog picture signal.
W-LEV	-32 ~ +31	Adjustment of the Contrast level for an analog picture signal. (If the AGC is at ON, a blank will be displayed.)
SHARP	-32 ~ +31	Picture quality adjustment for an analog picture signal. (If DIRECT switch is at ON, a blank will be displayed.)
AGC	ON/OFF	Function for setting a constant and a suitable value for the amplitude of the detected peak level signal.
DIRECT	ON/OFF	Function for manipulating the composite video signal without passing it through filter or quality correction circuit.
DITHER	ON/OFF	This function for selecting of print's gradation. OFF: 64 gradation ON: quasi 256 gradation

- The AGC automatically brightens an overall dark picture.
- When AGC is set at ON, "W-LEV" adjustment cannot be carried out.
- When DIRECT switch is set ON, "SHARP" adjustment cannot be carried out. Also, all filters set by the rear-panel's MODE switch will be rendered ineffective.
- A "dither" circuit improves the printing by increasing the gradation of each pixel (from 64 to 256)

- 3) Use the left/right SHIFT buttons to change in accordance with the desired value for each selection.



C WHEN OPERATION IS TO BE TERMINATED AT STEP 1

Press the SET button. If adjustment is to be continued to STEP 2, do not press SET button. Carry out STEP 2 operations next. The setting values for STEP 1 will be memorized automatically.



STEP 2

- Press the FUNCTION button once more. The monitor will show a display similar to that shown in the figure at right. However, if the setting of ①, ② and ③ of a-1 is made for other signals than the TV signal, the same picture as shown in [B] on page 33 will be displayed on the screen. This menu is for setting the print size and position. For details, refer to pages 51~55.

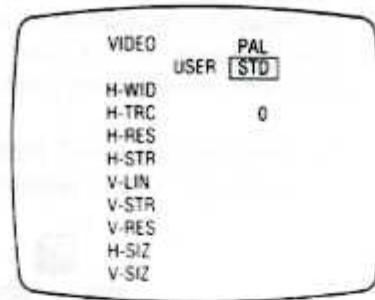

A WHEN USED WITH A STANDARD PICTURE

(When signals other than the TV signal are entered, don't use the standard picture.) The unit is already pre-set with 2 kinds of print modes "STD 2" and "STD 3". At "STD 2", the image will be printed as it is, while at "STD 3", it will be printed "under-scanned".

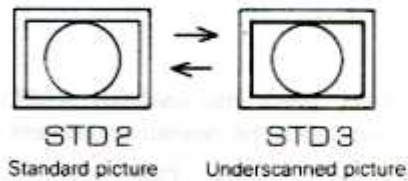

- 1) Press the right button once, the "STD" indication will change to "STD 2". (If "STD 3" has already been set, the change will be to "STD 3".)

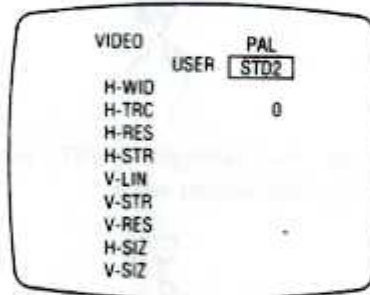
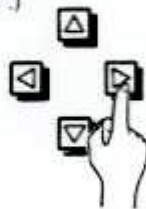

- 2) Next, press the up/down SHIFT button. At standard display, the change will be from 3 to 2. Choose the desired print mode.

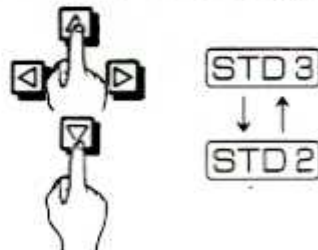

- 3) Once the print mode is determined, press the left SHIFT button. The display will return to "STD".

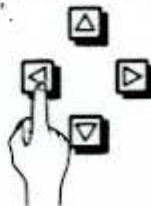

B WHEN THE PICTURE IS TO BE ADJUSTED.

- For details on the content of each adjustment, refer to pages 51~55. Carry out the adjustment after reading them carefully.

- 1) Press the left SHIFT button, and set the cursor on "USER" position.

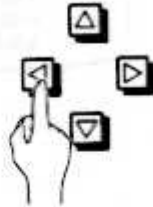

VIDEO	USER	PAL
	STD	
H-WID	770	770
H-TRC	0	0
H-RES	640	640
H-STR	42	42
V-LIN	625	625
V-STR	36	36
V-RES	580	580
H-SIZ	100	100
V-SIZ	75	75

- 2) Next, press the up/down SHIFT button, and select the desired adjustment article.

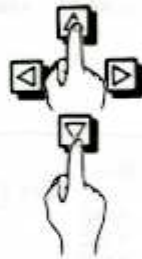

VIDEO	USER	PAL
	STD	
H-WID	770	770
H-TRC	0	0
H-RES	640	640
H-STR	42	42
V-LIN	625	625
V-STR	36	36
V-RES	580	580
H-SIZ	100	100
V-SIZ	75	75

- 3) Press the left/right SHIFT button to change the setting value.

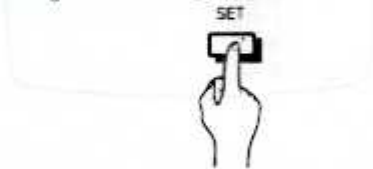

C WHEN PICTURE SETTINGS HAVE BEEN COMPLETED.

Press the SET button. The monitor's screen will return to normal display.

2. RGB-TTL SIGNAL INPUT

A) Input a signal from the RGB-TTL device.

B) Press to open the front door.
All buttons shown in the figure are inside.

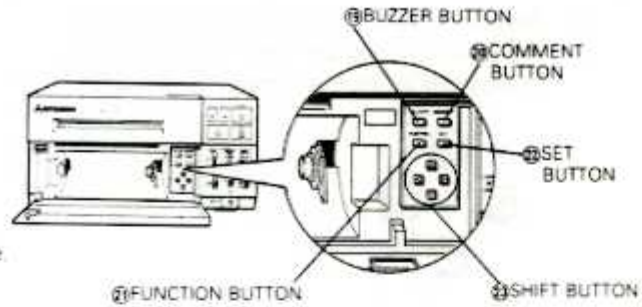

STEP 1

- There are no picture level signal adjustment operations for RGB-TTL mode.

STEP 2

- Press the FUNCTION button once.
The monitor screen will display the menu shown in the figure.
This display is for setting the print size or position. For details, refer to pages 51~55.

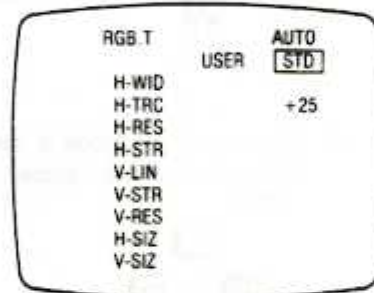

A WHEN USED WITH A STANDARD PICTURE

The unit has already been preset to RGB standard values conforming to all kinds of PC's RGB signals.

- The standard values conforming to TTL PC signals are listed in the following left table.
- a) Set MODE 1 selector (M₁ and M₂) on the rear panel in accordance with the connected computer – as in the following right table.

STANDARD No.	CONFORMABILITY TYPE
STD 6	IBM® CGA (Text/Graphic)
STD 7	IBM® EGA (Text/Graphic)
STD 8	IBM® MDA (Text)
STD 9	Hercules Graphic Card® (Graphic)

STANDARD No.	M ₁	M ₂
STD 6-7	OFF	ON
STD 8-9	OFF	OFF

MODE 1 Selector setting

Note: IBM is registered trademark of International Business Machines Corporation.

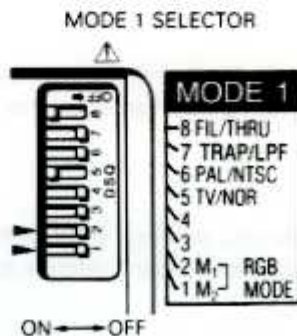

- The on-screen "AUTO" display appears in the upper-right corner of the menu.
- STD 6 or 7 selection is carried out automatically, and the standard values compatible to IBM® CGA/EGA will be set.
- Select STD 8 or 9 in accordance with the following (1) to (4) procedures.
- When M₁ is at "ON", each standard value, starting from STD 0, can be selected. Select in accordance with the following (1) - (4) procedures. At that time, on-screen "MANU" display appears in the upper right corner of the menu.

- 1) Press the right SHIFT button to change to "STD 0". (When all have been set, the display will be of the number of that STD.)

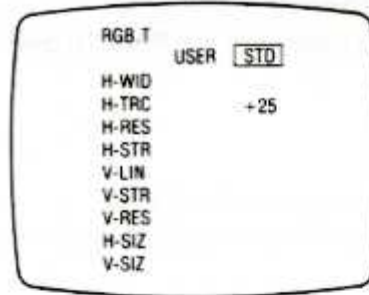
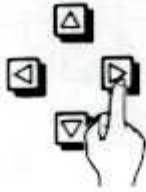

- 2) Next, press the up/down SHIFT button to change the STD value within STD 0 ~ STD 9. Select the standard conforming to the kind of connection.

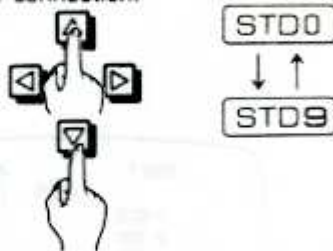

- 3) Once the print mode is determined, press left button. The display will return to "STD".



- 4) If noise appears on the screen of the monitor, use the shift buttons to correct the H-TRC value.

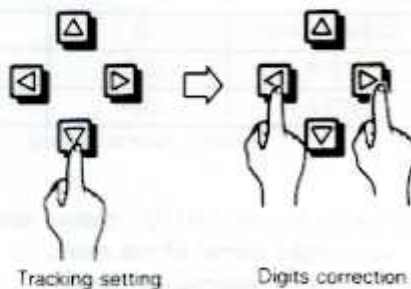

- In the case of a device whose connection kind does not conform to the standards, the procedure detailed in the next paragraph "When used at settings other than standards" should be followed.

[B] WHEN USED AT SETTINGS OTHER THAN STANDARDS.

If picture timing (synchronization) or print size are slightly different, or when settings for PC or signal of the RGB-TTL device differ from the standards, independent settings are necessary.

- The setting method is similar to "[B] WHEN THE PICTURE IS TO BE ADJUSTED" of page 33.

3. RGB-ANALOG SIGNAL INPUT

- A) After checking the setting on page 15 set the RGB ANALOG/TTL selector to the ANALOG side and input the signal from an RGB-analog device. The picture will be displayed on the screen of the monitor.
- B) Press to open the front door. All buttons shown in the figure are inside.

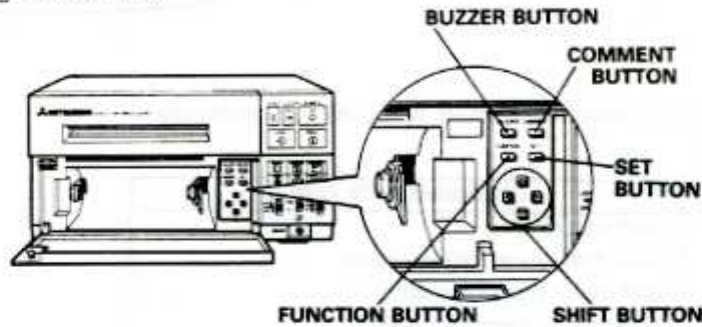

STEP 1

- Press the FUNCTION button once. The menu shown in the figure will overlap the monitor's screen. This menu is for adjusting the picture's black level and contrast of the input signal. The method of adjustment is similar to "1.INPUT OF VIDEO SIGNAL". (For details, refer to pages 30~33.)

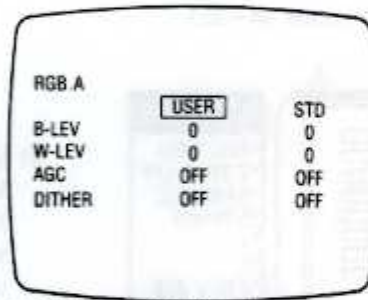

* SHARP and DIRECT adjustments are not possible in RGB-analog mode.

When operation is to be ended at STEP 1 only, press the SET button.

If operation is to be continued to STEP 2, do not press the SET button. Follow the procedure for STEP 2.

The setting values for STEP 1 will be memorized automatically.



STEP 2

- Press the FUNCTION button once. The monitor screen will display the menu shown in the figure.

This menu is for adjusting picture size or position.

For details, refer to pages 51~55.

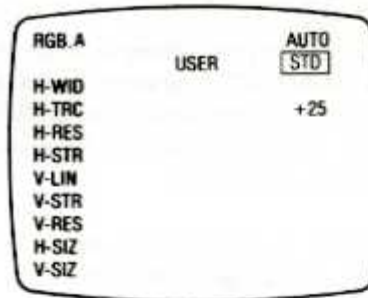

- The standard values conforming to RGB ANALOG PC signals are listed hereunder.

STANDARD No.	CONFORMABILITY TYPE
STD 0	IBM® PGC (Graphic)
STD 1	APPLE® Macintosh II (Text/Graphic)
STD 2	IBM® VGA 1 (Text) 720×400
STD 3	IBM® VGA 2 (Graphic) 640×400
STD 4	IBM® VGA 3 (Graphic) 640×350
STD 5	IBM® VGA 4 (Graphic) 640×480

- Setting method of others are similar to "2. RGB-TTL SIGNAL INPUT". (Refer to pages 34~35.)

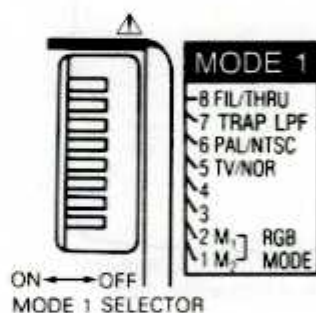

- When IBM® PS/2 is used, set M₁ of the rear panel's MODE1 selector to "OFF". Compatible standard value from the above STD 3, 4, or 5 will be automatically selected. On-screen "AUTO" display appears in the upper-right corner of the menu.

- When IBM® PS/2 is used at VGA TEXT mode, select STD 2 in accordance with (1) to (4) procedure on page 35. When selecting STD 2, compatible standard value from the above STD 2, 4, or 5 will be automatically selected.

- When devices other than IBM® PS/2 are used, set M₁ of MODE1 selector to "ON". As such, each standard value, starting from STD 0 and in sequence, can be selected.

COMMENT SETTINGS

- This unit allows one comment line (letters and codes) to be inserted below the print screen. Also, the number of total prints which were counted automatically can be printed in addition to the comment.

- Perform setting in the following manner when printing comments only.

STEP 3-1

1. Press the FUNCTION button three times. The screen shown in the right figure will be displayed on the monitor screen (tentative comments have been set).
2. Press the lower SHIFT button to move the cursor to the first letter frame.
3. Select the desired letter or code by using the up/down SHIFT button. The selected letters or codes are within the range shown in the right figure. Up to 80 letters can be set in this mode.
4. Press the right SHIFT button to move the cursor to the next letter frame. Use the up/down SHIFT button to select another letter or code.
5. Repeat 2 and 3 above and press the SET button after the desired comments have been displayed.
6. If the COMMENT button is pressed, the COMMENT indicator for the set frame will be lit and comments contents will be printed out during printing. If the COMMENT button is pressed again, the COMMENT indicator will be turned off and the set comments will not be printed out.

FUNCTION

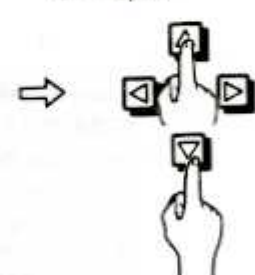
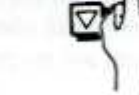
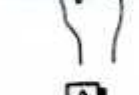
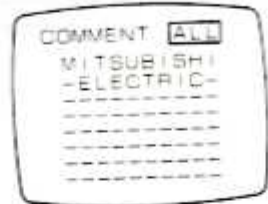

SET



Returns to normal display.

COMMENT



- Perform setting in the following manner when printing comments and total number of prints:

STEP 3-2

1. Press the FUNCTION button three times. The screen shown in the right figure will be displayed on the monitor screen (tentative comments have been set).

FUNCTION



2. Press the right or left SHIFT button once. Then, the monitor screen changes as shown in the right figure. The total number of prints is displayed at the lower right corner of screen.

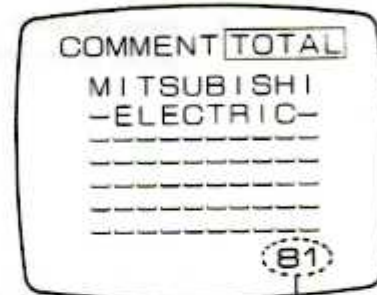

Total number of prints
Returns to the normal screen

3. See the STEP3-1 2-5 for how to set comments. Up to 70 letters can be set as a comment.

4. Press the SET button when the required comment has been displayed.

SET

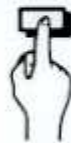

Returns to normal display.

5. If the COMMENT button is pressed, the COMMENT indicator on the front face will be lit and the comments contents and total number of prints will be printed out during printing.

COMMENT

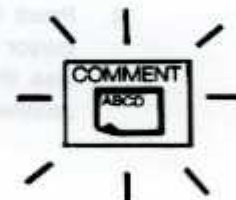

If the COMMENT button is pressed again, the COMMENT indicator will be turned off and the set comments will not be printed out.

INITIALIZATION OF SET VALUES

The set values in the function mode can be initialized (returned to the standard values at shipment) by the following operations.

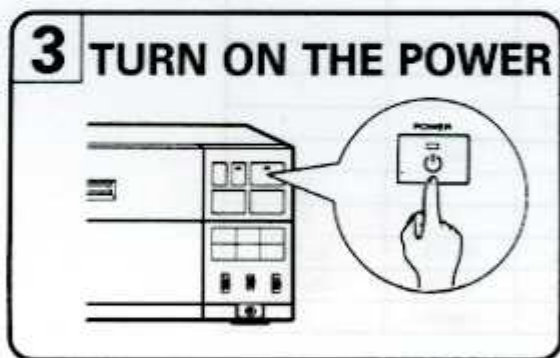
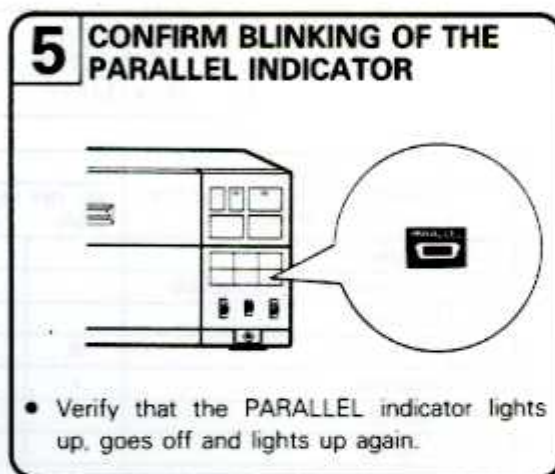
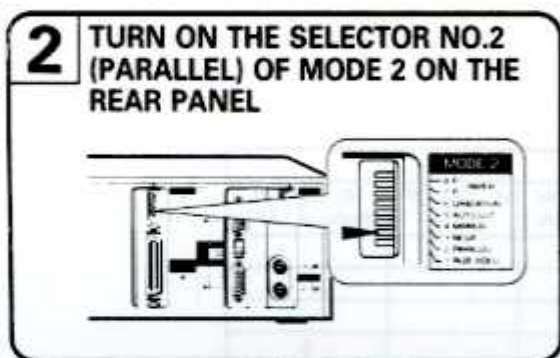
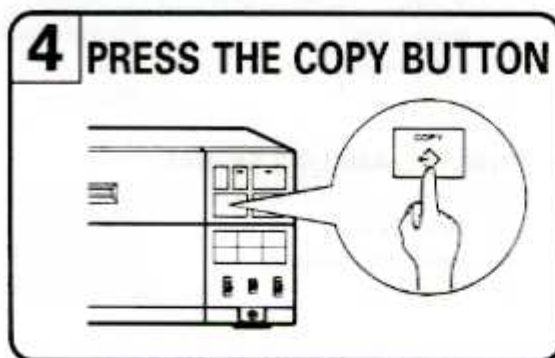
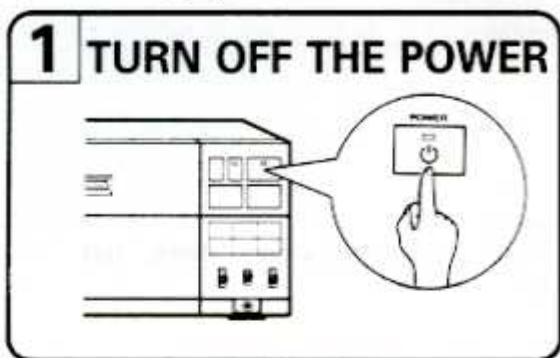

SPECIFICATIONS FOR INPUT SIGNALS

1. COMPOSITE VIDEO SIGNAL

STANDARD (PAL/SECAM/NTSC) COMPOSITE VIDEO SIGNAL

- 1) Input Level 1V p-p (input terminal)
- 2) Input Impedance 75Ω
- 3) Connector BNC type

2. RGB TTL/ANALOG SIGNAL

R.G.B.I HD · VD SEPARATE VIDEO SIGNAL

- 1) Input Level ANALOG 0.7 Vp-p/TTL
- 2) Input Impedance ANALOG-VIDEO 75Ω TTL-VIDEO 470Ω SYNC. 1kΩ
- 3) Connector D-SUB Mini 15 Pin

RGB IN RGB OUT

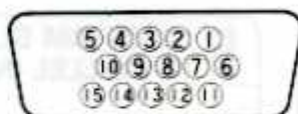

Pin #	ANALOG (IBM® PS/2, APPLE® Mac II or other Analog PCs)	TTL			
		M ₁ : OFF M ₂ : ON (EGA)	M ₁ : ON M ₂ : ON (CGA)	M ₁ , M ₂ : OFF (MDA)	M ₁ , M ₂ : ON (None of LEFT)
1	R Video				
2	G Video (Sync on G available)				
3	B Video				
4	reserved	B	B		B
5	reserved	r			
6	GND (R)				
7	GND (G)				
8	GND (B)				
9	GND (Sync)	GND	GND		
10	GND (Sync)	g		Video	
11	reserved	G	G		G
12	reserved	R	R		R
13	HS/CS/Hs/Cs	Hs	Hs	Hs/Hs	Hs/Hs
14	VS/Vs	Vs	Vs	Vs/Vs	Vs/Vs
15	reserved	b	I	Intensity	I

3. PARALLEL DATA SIGNAL (According to CENTRONICS® Interface)

- 1) • Input Level: TTL
- Connector: JD-36SL or equivalent

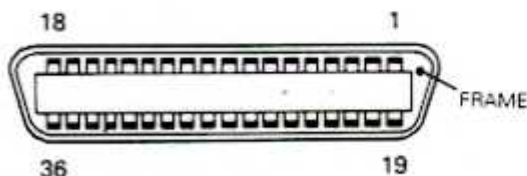

- Mode Types:
 - Character Mode
 - Line Scan Graphic Mode
 - 16-Gradation Dot Graphic Mode
 - 2-Gradation Dot Graphic Mode

4. PARALLEL INTERFACE TIMING

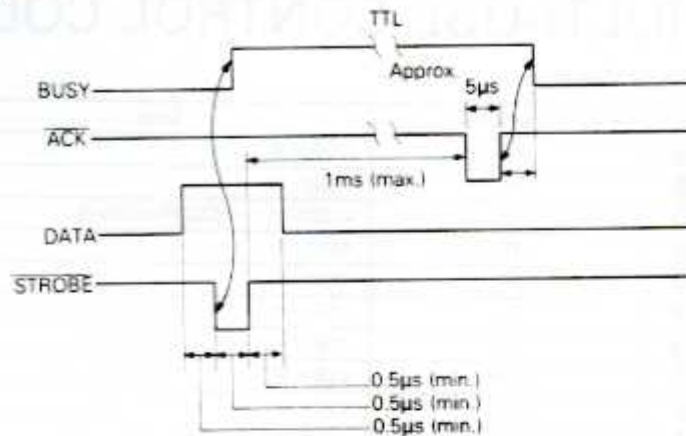

Standard Parallel Interface

- a) Input Connector
Plug 57-30360 (AMPHENOL Equivalent)
- b) Input Connector Signal Assignment

Pin No.	Pin No. Return Side	Signal	Signal Source	Function
1	19	STROBE	Computer	Strobe pulse for the data reading. Pulse width: over 0.5µs Normal "High" Data Reading "Low"
2	20	DATA 1	Computer	Each signal indicates the information of the parallel data from 1 bit till 8 bit. High - Data 1 Low - Data 0
3	21	DATA 2	Computer	
4	22	DATA 3	Computer	
5	23	DATA 4	Computer	
6	24	DATA 5	Computer	
7	25	DATA 6	Computer	
8	26	DATA 7	Computer	
9	27	DATA 8	Computer	
10	28	ACK	Video Copy Processor	Low indicates that the printer received the data and is ready to receive the next data.
11	29	BUSY	Video Copy Processor	High signifies that the Video Copy Processor can not accept the data. Low indicates that the Video Copy Processor can accept the data. In the next case, this signal will be changed to High. 1 While the data is entered. 2 While printing is on. 3 While paper is being fed. 4 While PE or SELECT is "LOW" condition. 5 While ERROR is "LOW" condition.
12		P - E	"	Paper supply Low: available High: Not available
13		SELECT	Video Copy Processor	When the Video Copy Processor is not at "ERROR" conditions, VCP is selected with DC1/DC3 controls, it will be kept during "HIGH".
14, 15		NC		Unused
16, 17		GND		GND
18		NC		Unused
19-30		GND		GND level signal for Twist Pair Return.
31		NC		Unused
32		ERROR	Video Copy Processor	"LOW": when the Video Copy Processor is at "ERROR" due to the following: <1> No-paper conditions <2> Off-line conditions <3> Over-heat or humidity accumulation on the Thermal-Head. <4> "PAPER JAMMED" conditions
33		GND		GND level signal for Twist Pair Return.
34-36		NC		Unused

MULTI-USE CONTROL CODES

Control Code

	Code Name	Code	Function
①	LF	<0A> H	Print and line feed
②	VT	<0B> H	Same as LF
③	CR	<0D> H or <0D>H<0A>H	Same as LF
④	FF	<0C> H	Print and line feed
⑤	HT	<09> H	8 characters horizon tab
⑥	SO	<0E> H	Double width magnified character
⑦	SI	<0F> H	SO reset
⑧	CAN	<1B> H	Cancel
⑨	DEL	<7F> H	Same as CAN
⑩	DC3	<13> H	Printer deselect
⑪	DC1	<11> H	Printer select
⑫	BEL	<07> H	Buzzer for 1 second
⑬	ESC P	<1B> H <50> H	Print
⑭	ESC Y	<1B> H <59> H	Copy
⑮	ESC E	<1B> H <45> H	Feed
⑯	ESC T	<1B> H <54> H	Cut
⑰	ESC N	<1B> H <4E> H	Comment
⑱	ESC B	<1B> H <42> H	Buzzer SW ON/OFF
⑲	ESC O	<1B> H <30> H	No line space
⑳	ESC Z	<1B> H <32> H	6 dot line space
㉑	ESC 8	<1B> H <38> H	
㉒	ESC 9	<1B> H <39> H	Auto line feed
㉓	ESC L (m)	<1B> H <4C> H <m> H	1 page length set
㉔	ESC C (m)	<1B> H <43> H <m> H	Print set
㉕	ESC W (0)	<1B> H <57> H <00> H <XS1> H <XS2> H <YS1> H <YS2> H <XE1> H <XE2> H <YE1> H <YE2> H <DATA2, DATA1> H <DATA4, DATA3> H -----	16-gradation dot graphic mode
㉖	ESC W (1)	<1B> H <57> H <01> H <XS1> H <XS2> H <YS1> H <YS2> H <XE1> H <XE2> H <YE1> H <YE2> H <DATA8, DATA7, DATA6, DATA5, DATA4, DATA3, DATA2, DATA1> H <-----> H -----	2-gradation dot graphic mode
㉗	ESC F	<1B> <46> <Function No.> <TYPE> <DATA1> H	Function set

When the power switch is turned on in the parallel mode, the unit functions as a page printer that is set to 80 characters × 25 lines in one page.

When the printing data (including a space) for one page is entered, the unit automatically prints that data in one page. If the input data is less than one page, enter a FF code or press the PRINT key on the front panel to print the data.

DESCRIPTION OF MULTI-USE CONTROL CODES

① LF

1. Name: Line feed
2. Code: <OA> H
3. Function: With the LF code entered, line feed is performed in the print buffer.

② VT

1. Name: Vertical tabulation
2. Code: <OB> H
3. Function: Same as LF.

③ CR

1. Name: Carriage return
2. Code: <OD> H or <OD> H <OA> H
3. Function: Same as LF

Note) When <OD> and <OA> are continuously entered, the function of <OA> is ignored.

④ FF

1. Name: Form feed
2. Code: <OC> H
3. Function: With the FF code entered, the data in the print buffer is printed and the beginning of the next page is searched according to the preset page length.
 - The beginning of a page is set when the power switch is turned on.
 - A page length is set to 25 lines when the power switch is turned on.

⑤ HT

1. Name: Horizontal tabulation
2. Code: <09> H
3. Function: Cursor movement in units of 8 characters (Standard character size is taken as a unit even when a double width magnified character is used.)

Example) <30>H <09>H <31>H <32>H <33>H 0 123
 └──┘ └──┘ └──┘ └──┘ └──┘ ┌──────────┐
 0 HT 1 2 3 8 characters

⑥ SO

1. Name: Shift out
2. Code: <OE> H
3. Function: With the SO code entered, the following data is printed in double width magnified characters.
 - The SO code is reset by the SI code.
4. Example: ! " # \$ % & ' < > * + , - . / 0 1 2 3

↓

! " # \$ % & ' < > * + , - . / 0 1 2 3

⑦ SI

1. Name: Shift in
2. Code: <OF> H
3. Function: With the SI code entered, double width magnified character is reset.

⑥ CAN

1. Name: Cancel
2. Code: <1B> H
3. Function: With the CAN code entered, the data in the print buffer that has been entered in the same line before the CAN code is canceled.

⑦ DEL

1. Name: Delete
2. Code: <7F> H
3. Function: Same as the CAN code.

⑩ DC3

1. Name: Device control 3
..... Printer deselect
2. Code: <13> H
3. Function: With the DC3 code entered, the printer is set to the deselect state (electrically connected, but separated functionally).
 - When the DC1 code is entered, the printer is restored to the select state.

⑪ DC1

1. Name: Device control 1
2. Code: <11> H
3. Function: With the DC1 code entered, the printer is set to the select state and data transfer is enabled.
 - This code is valid only for returning from the printer deselect state with the DC3 code.

⑫ BEL

1. Name: Bell
2. Code: <07> H
3. Function: With the BEL code entered, the buzzer sounds for one second.

⑬ ESC P

1. Name: Print
2. Code: <1B> H <50> H
3. Function: When an input signal is entered, it is printed according to the setting of the MODE2 #1 RGB/VIDEO selector switch.

⑭ ESC Y

1. Name: Copy
2. Code: <1B> H <59> H
3. Function: A printed screen is copied.

⑮ ESC E

1. Name: Feed
2. Code: <1B> H <45> H
3. Function: With the ESC E code entered, the paper is fed about 32mm.

⑯ ESC T

1. Name: Cut
2. Code: <1B> H <54> H
3. Function: With the ESC T code entered, the paper is cut.
(The paper is fed back about 14mm after initially cut.)

17 ESC N

1. Name: Comment
2. Code: <1B> H <4E> H
3. Function: With the ESC N code entered, ON/OFF of comment is switched.

18 ESC B

1. Name: Buzzer
2. Code: <1B> H <42> H
3. Function: With the ESC B code entered, ON/OFF of buzzer sound before and after PRINT is switched.

The above function 17~18 correspond to the front key. The initial value in the Centronics mode of 17, 18 correspond to the state selected by the front key before the mode is set.

19 ESC 0

1. Name: Setting for omission of line space
2. Code: <1B> H <30> H
3. Function: With the ESC 0 code entered, the subsequent font printing is set for 10-line printing. See Fig. A.

20 ESC 2

1. Name: Setting for line space 6-dot line
2. Code: <1B> H <32> H
3. Function: With the ESC 2 code entered, the subsequent font printing is set for 16-line printing. 16-line printing is set in the initial state. See Fig. A.

8×16 dots are used for one character in font as illustrated on the left. An actual font data is 8×10 dots and 00 is usually included in lower 8×6 dots. Therefore, the 6 dots correspond to a line space. Whether or not to print this part is determined by ESC 0 and ESC 2.

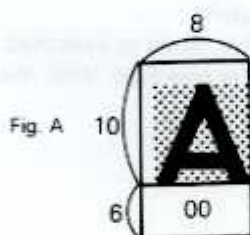

21 ESC 8

1. Name: Auto line feed
2. Code: <1B> H <38> H
3. Function: A line is automatically fed when 80 characters are printed in one line. Initial state when the power switch is turned on.

22 ESC 9

1. Name: Reset of auto line feed
2. Code: <1B> H <39> H
3. Function: A line is not fed until CR or LF is entered. When the number of characters exceeds 80, the data is rewritten from the beginning of a line.

23 ESC L (m)

1. Name: Setting of page length
2. Code: <1B> <4C> <m> H (<1> H ≤ <m> H ≤ <32> H)
3. Function: Page length is set in character line units.
 - <m> H indicates the number of lines by a hexadecimal number.
 - When the power switch is turned on, the number of lines is set to 25 character lines.

24 ESC C (m)

1. Name: Print set
2. Code: <1B> H <43> H <m> H

As for 23 above, the state is the same as setting of DIP switch, SLIDE switch until it is set.

3. Function:

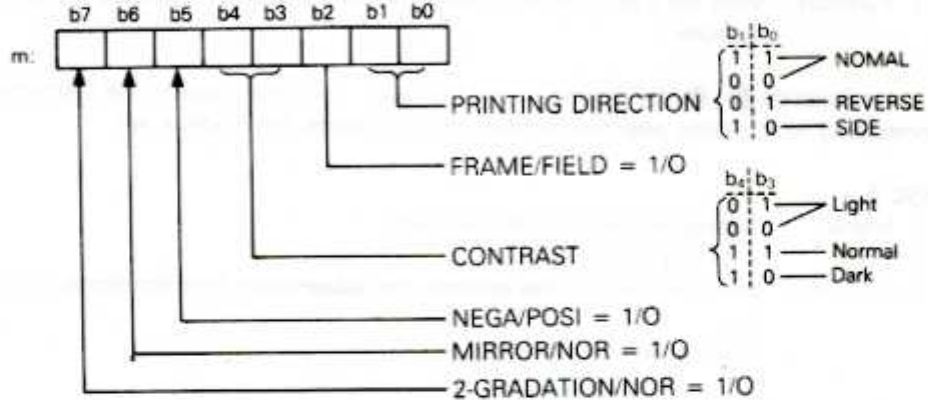

25 ESC W (0): Can not be set unless SYNC of VIDEO or RGB signal is entered.

1. Name: 16-gradation dot graphic mode
2. Code: <1B>H <57>H <00>H <XS1>H <XS2>H <YS1>H <YS2>H <XE1>H <XE2>H <YE1>H <YE2>H <DATA2 DATA1>H <DATA4 DATA3>H ... <DATA_n DATA_{n-1}>H

3. Function: With the ESC W(0) code entered, the 16-gradation dot graphic mode is executed. With the subsequent XS, YS, XE and YE, the transfer range is specified. With the subsequent <DATA>, picture elements and data are sent.

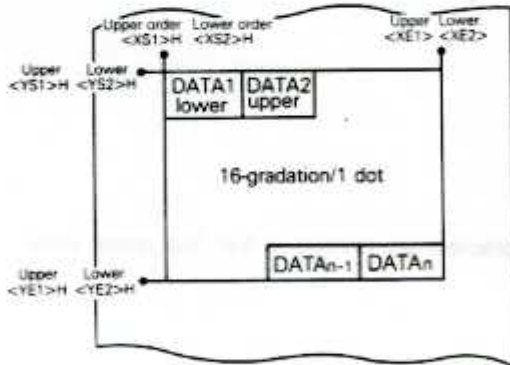

Note 1) $1 \leq XS \leq XE \leq H-RES$
 $1 \leq YS \leq YE \leq V-RES$

Note 2) As 0 → F, black turns to white.

Note 3) 1 dot is expressed by 4 bits. (16-gradation)

Note 4) Normal operation is not obtained unless the number of transfer data is equal to or more than $(XE - XS + 1) (YE - YS + 1) \div 2$.

Note 5) When the specified range is filled with data, the data is printed out.

4. Example:



A) Specification of setting range

Upper	Lower	Decimal number	Hexadecimal number
<XS1>H	<XS2>H	50	<00>H <32>H
<YS1>H	<YS2>H	300	<01>H <2C>H
<XE1>H	<XE2>H	58	<00>H <3A>H
<YE1>H	<YE2>H	301	<01>H <2D>H

B) Preparation of data

DATA = <20>H <64>H <A8>H <EC>H <FF>H <CE>H <8A>H <46>H <02>H

C) All the data to transfer the above screen

<1B> <57> <00> <00> <32> <01>H <2C>H <00>
 <3A> <01>H <2D>H <20> <64> <A8> <EC> <FF>
 <CE> <8A> <46> <02>

Print out the above screen with these data.

29 **ESC W(1):** Can not be set unless VIDEO or RGB signal is entered.

1. Name: 2-gradation dot-graphic mode

2. Code: <1B> H <57> H <01> H <XS1> H <XS2> H <YS1> H
 <YS2> H <XE1> H <XE2> H <YE1> H <YE2> H
 <DATA8 DATA7 DATA6 DATA5 DATA4 DATA3 DATA2 DATA1> H

3. Function: With the ESC W(1) code entered, the 2-gradation dot graphic mode is executed. With the subsequent XS, YS, XE and YE, the transfer range is specified. With the subsequent DATA, the picture element data is sent. DATA 1 dot is expressed by one bit and 0/1 is printed in black/white.

Note 1) $1 \leq XS \leq XE \leq H-RES$
 $1 \leq YS \leq YE \leq V-RES$

Note 2) 0/1 = BRACK / WHITE

Note 3) 1 dot is expressed by 1 bit (2-gradation)

Note 4) Normal operation is not obtained unless the number of transfer data is equal to or more than $((XE - XS + 1) (YE - YS + 1) + 8)$

Note 5) When the specified range is filled with data, the data is printed out.

4. Example:

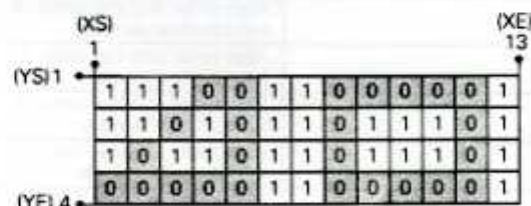

A) Setting range

Upper	Lower	Decimal number	Hexadecimal number
<XS1>H	<XS2>H	1	<00>H <01>H
<YS1>H	<YS2>H	1	<00>H <01>H
<XE1>H	<XE2>H	13	<00>H <04>H
<YE1>H	<YE2>H	4	<00>H <04>H

B) Preparation of data

DATA = <67>H <70>H <ED>H <B6>H <5D>H <30>H <F8>H

C) All the data to transfer the above screen

<1B> <57> <01> <00> <01> <00> <01> <00> <0D> <00>
 <04> <67> <70> <ED> <B6> <5D> <30> <F8>

2) Centro Functions

ESC + "F" + FUNCTION NO. + TYPE + DATA 1 + DATA 2 + _____
 e.g. <IB>H <46>H <02>H <81>H <UPPER>H <LOWER>H

Function No.	Type	Meaning	Data format	Number of data
<01>H	—	FUNCTION 1		
	<00>H	USER → STD switching	—	—
	<01>H	B-LEV	Complement of 2 in case of a negative hexadecimal number	1
	<02>H	W-LEV	Complement of 2 in case of a negative hexadecimal number	1
	<03>H	SHARP* ⁽²⁾	Complement of 2 in case of a negative hexadecimal number	1
	<04>H	AGC	<01>H at ON	1
	<05>H	DIRECT* ⁽²⁾	<00>H at OFF	1
<02>H	—	FUNCTION 2		
	<00>H	USER → STD switching	—	—
	<01>H	USER ← STD switching	—	—
	<10>H	USER → STD0 switching	—	—
	<11>H	USER → STD1 switching	—	—
	<12>H	USER → STD2 switching	—	—
	<13>H	USER → STD3 switching	—	—
	<14>H	USER → STD4 switching	—	—
	<15>H	USER → STD5 switching	—	—
	<16>H	USER → STD6 switching	—	—
	<17>H	USER → STD7 switching	—	—
	<18>H	USER → STD8 switching	—	—
	<81>H	H-WID	High order and low order of hexadecimal number	2
	<82>H	H-TRC	Hexadecimal number (complement of 2 in case of negative)	1
	<83>H	H-RES	High order and low order of hexadecimal number	2
	<84>H	H-STR	High order and low order of hexadecimal number	2
	<85>H	H-STR	High order and low order of hexadecimal number	2
	<86>H	H-RES	High order and low order of hexadecimal number	2
	<87>H	H-SIZE	High order and low order of hexadecimal numbers	2
<88>H	H-SIZE	(16-decimal/byte)	1	
<03>H	—	FUNCTION 3		
	<00>H	Set comment character	Number of comment+ASCII CODE+	Up to 63
	<01>H	Set picture element number+Display comment 62 characters	—	—
	<02>H	Set picture element number+Display comment character number+print number	—	—

*⁽¹⁾ When the RGB-TTL signal is inputted, this function will be void.

*⁽²⁾ When the RGB-TTL or RGB-ANALOG signals are inputted, these items will be void.

CHARACTER CODES

LOWER 4 BIT	UPPER 4 BIT															
	FUNCTIONS		CHARACTERS													
	0	1	2	3	4	5	6	7	8	9	A	B	C	D	E	F
0	NUL		SP	0	w	P	.	p			SP	-	a	A	σ	≡
1		DC1	!	1	A	O	a	q			A	Y	e	i	β	z
2			"	2	B	R	b	r			Á	Y	ó	φ	Γ	≥
3		DC3	#	3	C	S	c	s			E	'	ú	Æ	τ	≤
4			\$	4	D	T	d	t			Ê	Ç	à	a	Σ	⌋
5			%	5	E	U	e	u			E	Ç	e	l	σ	⌋
6			&	6	F	V	f	v			İ	N	o	φ	μ	-
7	BEL		'	7	G	W	g	w			İ	n	u	æ	τ	κ
8		CAN	(8	H	X	h	x				i	a	A	φ	o
9	HT)	9	I	Y	i	y			'	l	e	l	⊕	•
A	LF		⌘	:	J	Z	j	z			^	o	b	O	Ω	-
B	VT	ESC	+	;	K		k					E	u	U	δ	√
C	FF		,	<	L	\	l	;			~	v	a	E	x	°
D	(CR)		-	=	M		m				U	š	e	i	φ	²
E	SO		.	>	N	^	n	~			Ú	f	o	B	€	■
F	SI		/	?	O	-	o	DEL			E	c	u	ö	∅	SP

NOTE: SP means the space

USER ADJUSTMENTS

1. ADJUSTMENT ITEMS

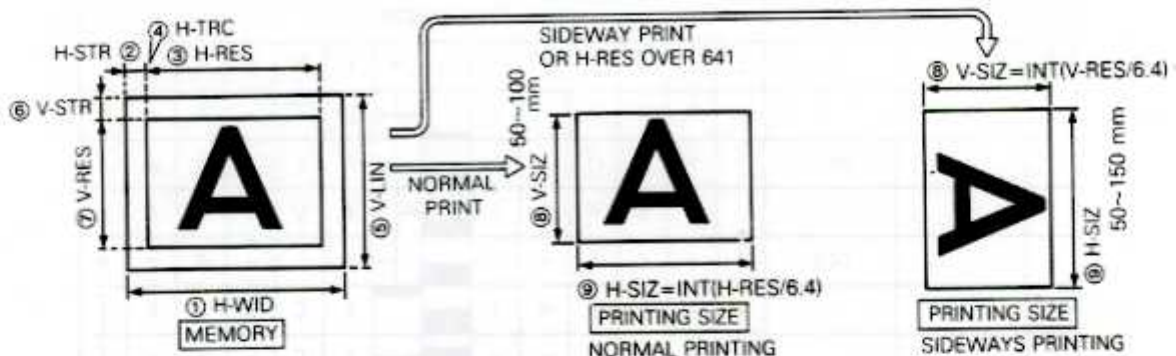

- ① H-WID (Total number of dots during H scanning)
H-WID sets the total number of dot clocks emitted in one horizontal scanning period including a horizontal blanking period. Owing to the difference in the dot clock number of the input signal, a beat interference stripes may appear on the CRT screen.



When phase-differences occur, beat-interference stripes appear
If there were 4 columns of these stripes, it will indicate for a 4-dot lag in H-WID. If there were 2 columns, a lag of 2-dot is present.

- ② H-STR (H display start position)
H-STR will be set by dot-clock units (from end of H SYNC signal to H display start).
- ③ H-RES (H display width)
H-RES will be set by dot-clock units (display period for each horizontal scan). As changes in the numerical values for H-WID settings of ① are accompanied with changes in the spacing of the dot-clock, the display width of the picture on the screen will change too. Determine the display range by means of H-RES.

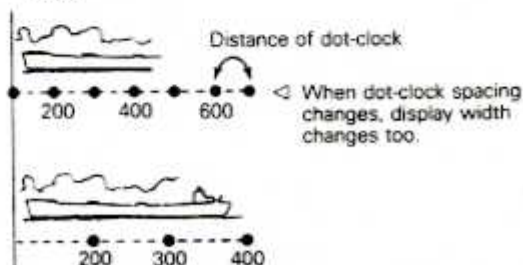

When H-RES is set over 641, the image will be printed out sideways.
However, In case of DIRECTION SELECTOR is set except "SIDE", the printing width are decided by seeing value of V-RES.

- ④ H-TRC
H-TRC changes the phase of the dot-clock by 64 steps.
After co-adjustment with H-WID, re-adjust it if noise still remains.



When noise still remains.

- ⑤ V-LIN (Total number of lines during V scanning)
V-LIN of input signal is automatically set in response to the signal inputted by line units (V scanning period including V line return period).
The numerical setting values cannot be changed.
- ⑥ V-STR (V display start position)
V-STR will be set at one line unit (from end of V SYNC signal to V display start).
- ⑦ V-RES (V display width)
V-RES will be set at one line unit (display duration for vertical scan).

⑧ V-SIZ

This sets the vertical printing width of the picture in 1mm units.

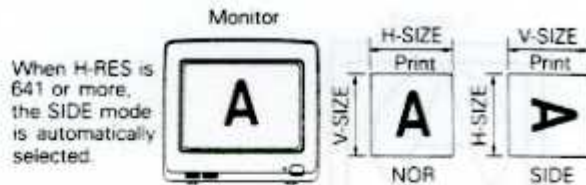

However, if the SIDE mode is already set or H-RES is more than 641, the V-SIZ is fixed and the printing width varies according to the value of V-RES.

⑨ H-SIZ

This sets the horizontal printing width of the picture.

When the normal print (NOR) mode is selected or H-RES is 640 or less, the printing width varies according to the value of H-RES. When the SIDE mode is already set or H-RES is 640 or more, set the vertical printing width in 1mm units.

Note: There are following conditions among item ① to ⑦.

- a. $[H-WID] \geq [H-RES] + [H-STR] + 72$
- b. $[V-LIN] \geq [V-RES] + [V-STR] + n$
 $n=4$; Non-interlaced
 $n=9$; Interlaced
- c. $[H-RES] \times [V-RES] < 490,300$

2. SETTING EXAMPLE

A. H TIMING SETTING

- The H validity duration for picture memorization will be set in accordance with H-WID and H-RES.
- Print width (H-SIZ) is constant.

EXAMPLE 1

Out of 800 parts for 1 H period (H-WID), 640 (H-RES) of picture are memorized as the validity period.

When printed, the result will be as in Fig. 1.

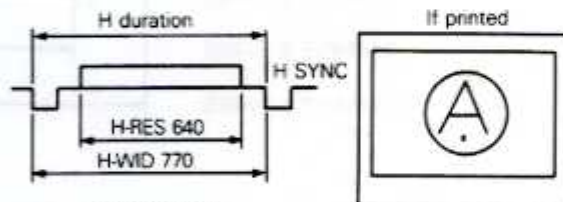

Fig. 1

EXAMPLE 2

When H-WID is changed to 900, out of 900, 640 (H-RES) become the validity period, and in accordance with EXAMPLE 1, the picture is memorized in a thin range.

Now, in accordance with EXAMPLE 1, as printing is carried out for the thin range of the picture in the same print width, the printed picture will be extended to the sides – as shown in Fig. 2

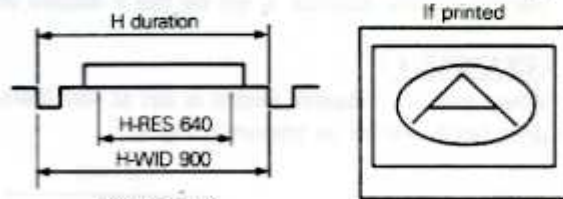

Fig. 2

When H-WID is enlarged

EXAMPLE 3

When H-WID is changed to 750, out of 750, 640 (H-RES) become the validity period, and in accordance with EXAMPLE 1, the picture is memorized in a wide range.

Now, in accordance with EXAMPLE 1, as printing is carried out for the wide range of the picture in the same print width, the printed picture will be elongated – as shown in Fig. 3.

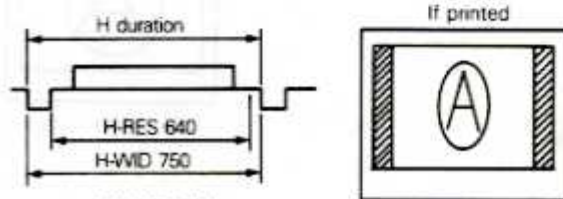

Fig. 3

When H-WID is reduced

○ **Distortion correction**

In the settings of EXAMPLE 2, the image is extended, while in that of EXAMPLE 3 it is condensed. To print in the correct ratio.

○ **Correction for EXAMPLE 2**

In this case, enlarge V-SIZ (V printing width). As the print picture will be enlarged in height, the distortion will be corrected. (Fig. 4)

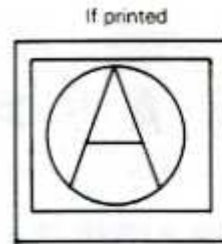

Fig. 4
When V-SIZE Is enlarged.

○ **Correction for EXAMPLE 3**

In this case reduce V-SIZ (V printing width). As the print picture will be reduced in height, the distortion will be corrected. (Fig. 5)

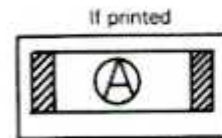
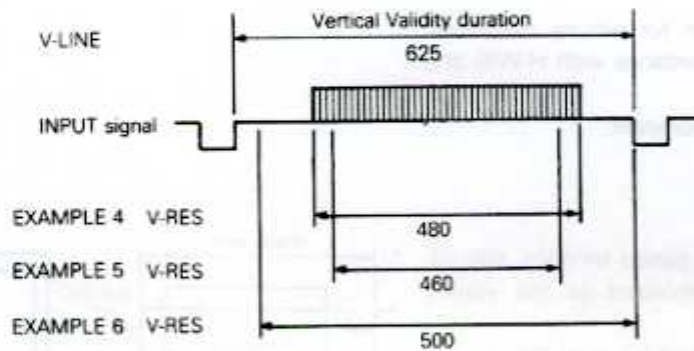

Fig. 5
When V-SIZE is reduced.

B. VERTICAL TIMING SETTINGS



As the number of scanning lines (V-LIN) are determined by the input signal, vertical validity duration is set by the V display width (V-RES) only.

EXAMPLE 4

When V-RES (V display width) is set at 480 lines, print finish will be as shown in Fig. 6.

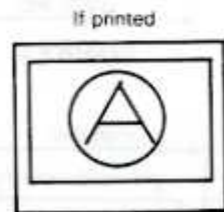

V-RES at 480 Fig. 6

EXAMPLE 5

When it is made larger than EXAMPLE 4.
When V-RES (V display width) is reduced even further than EXAMPLE 4 – to 460, the picture width will be thinner. As printing is carried out in the same width, the printed image will be elongated further – as shown in Fig. 7.

EXAMPLE 6

When it is made smaller than EXAMPLE 1.
When V-RES (V display width) is made larger than in EXAMPLE 4 – to 500, the picture width will be wider. As printing is carried out in the same width, the printed image will be extended further – as shown in Fig. 8.

○ **Distortion correction**

As shown in EXAMPLE 5 and EXAMPLE 4, prints of the picture can be elongated or extended. In order to correct the ratio;

○ **Correction for EXAMPLE 5**

In this case reduce V-SIZ (V printing width).
As the print picture will be reduced in height, the distortion will be corrected.

(Fig. 9)

○ **Correction for EXAMPLE 6**

In this case enlarge V-SIZ (V printing width).
As the print picture will be enlarged in height, the distortion will be corrected.

(Fig. 10)

if printed Fig 7

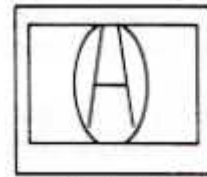

V-RES is made smaller

if printed Fig 8

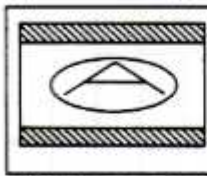

V-RES is made large

If printed Fig 9

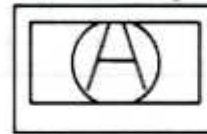

V-SIZ is made smaller

if printed Fig 10

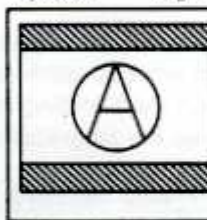

V-SIZ is made larger

3. WHEN CONNECTED TO PC'S AND OTHER DEVICES (H-WID/H-TRC)

When the unit is connected to a PC or another device, it would be necessary to adjust the H-WID in the input signal as the dot-clock for the latter is predetermined.

Now, if the input signal is to include a longitudinal black/white signal at each dot, when one line is looked at;

As in ①, when sampling is done at the same 1 dot lead of the input signal, the input signal will be sampled at the same black/white pattern.

However, as in ②, if sampling is carried out at a lead longer than 1 dot, or as in ③, if it is carried out at a shorter lead, alternation of black and white will lag, and white, white/black, black pattern will appear. In order to eliminate this beat interference, it would be necessary to change the sampling SYNC so it is matched with the dot-clock.

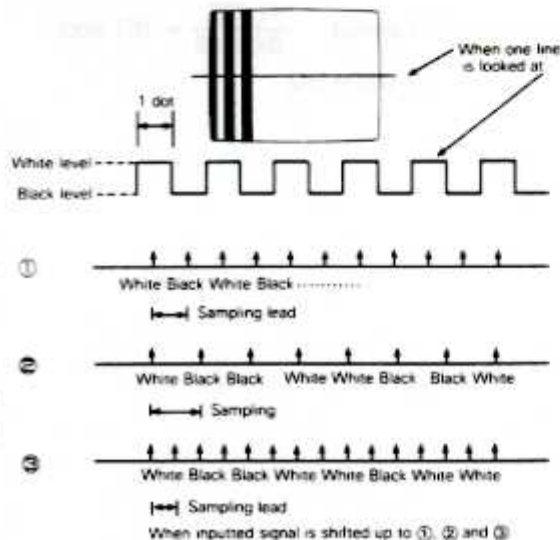

This sampling SYNC adjustment is carried out by H-WID.

In the case of ②, sampling SYNC is slow. Enlarge H-WID so that the lead becomes shorter.

In the case of ③, sampling SYNC is fast. Reduce H-WID so that the lead becomes longer.

Though the dot-clock of the input signal is matched with the sampling SYNC, there are cases in which correct sampling at points within a 1 dot range cannot be carried out.

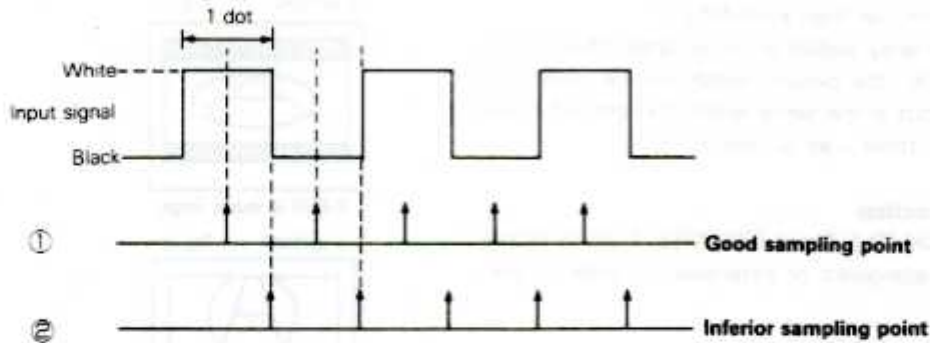

Sampling case within 1 dot is good – as in ①, however, as shown in sampling at the point of transition from white to black dot ②, correct black/white sampling cannot be carried out.

Accordingly, adjust the Sampling phase so that it attains the sampling points of ①.

This is adjusted via the 64-gradations (within 1 dot) of H-TRC.

EXAMPLE OF H-WID SETTING

H SYNC frequency	In case of 24kHz
Image period	In case of 35 μsec
H image dots	In case of 640 dots
Image 1 dot lead	$35/640 = 0.05469 \mu\text{s/dot}$
1 H period duration	$1 \div (24 \times 10^3) = 41.666 \mu\text{s}$
Total dots for 1 H period	$\frac{41.666}{0.05469} = 762 \text{ dots}$
∴ H-WID=762	

CAUTION

For maximum enjoyment and safe operation of your MITSUBISHI Video Copy Processor please read the enclosed leaflet "Important Safety Guards" carefully and apply them properly.

CALLING FOR SERVICE

Before requesting service please review this instruction book to correct minor complaints. If you are unable to correct the problem, consult your MITSUBISHI Dealer or MITSUBISHI Service Department.

DO NOT ADJUST ANY CONTROLS NOT DESCRIBED IN THIS INSTRUCTION BOOK.

DO NOT REMOVE THE PROTECTIVE ENCLOSURE OF THIS UNIT.